

**Studio  
London.**

**Amara Sideboard - Oak Finish**  
Stock number: SLAMASBMEL02

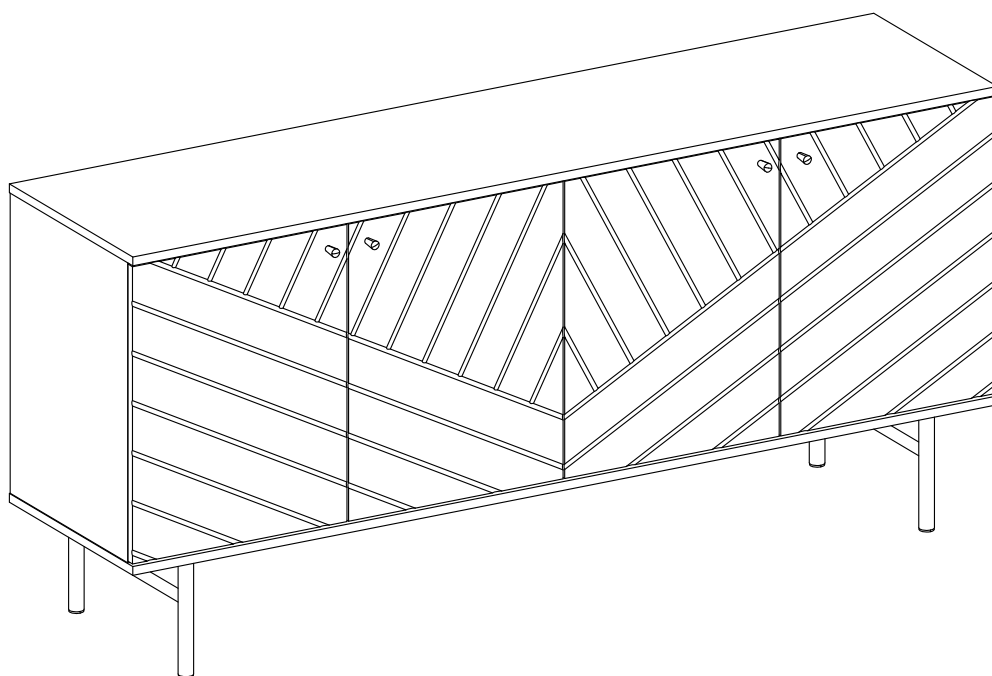

**62.9"W x 15.5"D x 29.3"H**

Congratulations on your purchase from Studio London!

In buying one of our quality products, you now own an item we sincerely hope you will love for years to come, without it coating the earth.

Responsibility is one of our core brand values. For every item sold, a tree is planted. Additionally, we invest in carbon reducing schemes, ensure all our materials are sustainable and responsibly sourced, and audit our suppliers to ensure they are safe, supportive and ethically sound.

We hope you love your item. We would love to hear any feedback or comment.

Visit us at [www.studiolondon.net](http://www.studiolondon.net) to comment or to find out more, and please follow us on instagram at [studio\\_london\\_design](https://www.instagram.com/studio_london_design).

### Tools required

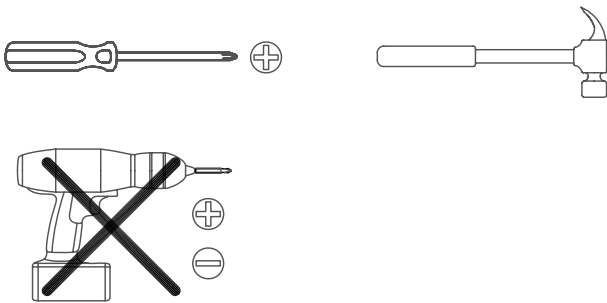

Don't use an electric screwdriver to assemble the cabinet panels.

### Wall attachment

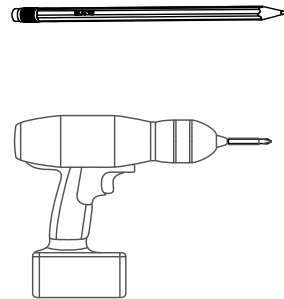

**Time to assemble**  
60 mins

**People to assemble**

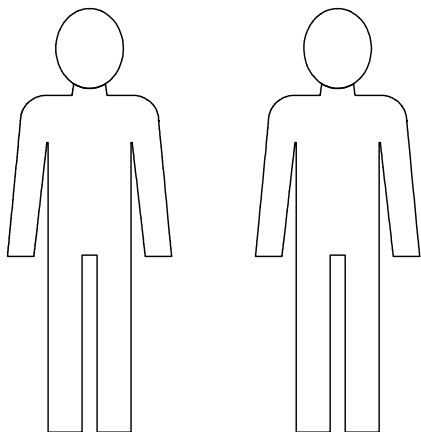

## Important safety information

### Warnings

- ⚠ **This product is not suitable for bedrooms.**
- ⚠ The product should only be used on firm, level ground.
- ⚠ Keep small parts out of reach of children.
- ⚠ Ensure the product is fully assembled as illustrated before use.

### Do's

- ✓ Check the pack and make sure you have all the parts listed.
- ✓ Check all screws or bolts are tightened and inspect regularly.
- ✓ Make sure the legs remain in contact with the ground all time.

### Don't

- ✗ Do not over tighten screws or bolts.
- ✗ Do not stand on the product.
- ✗ Do not use power tools to construct as overtightening and panel failure may occur.

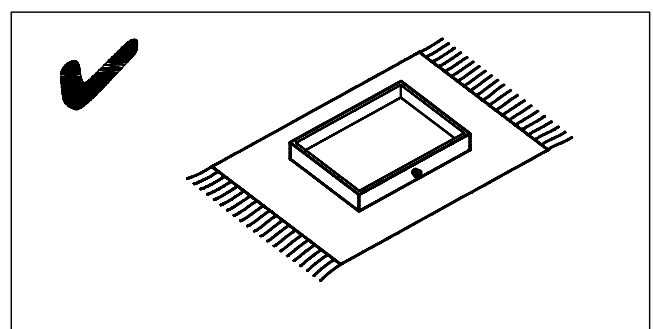
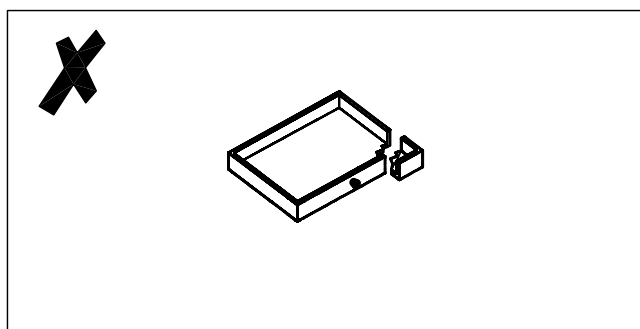
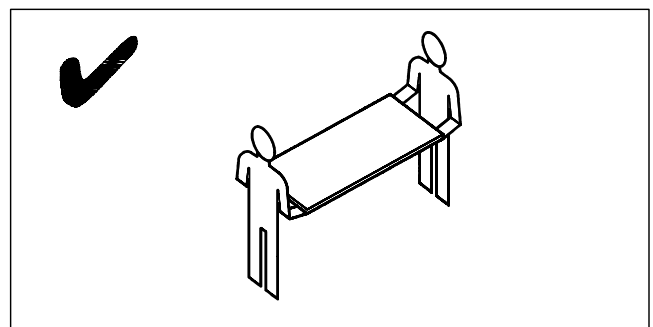
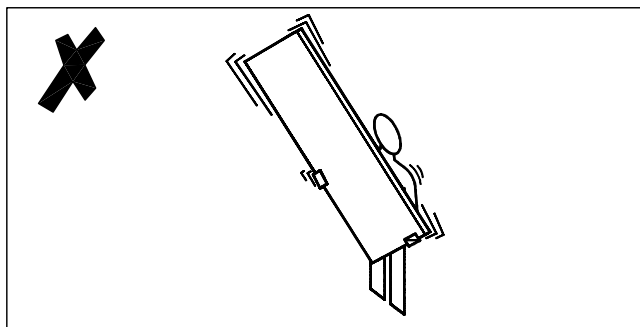
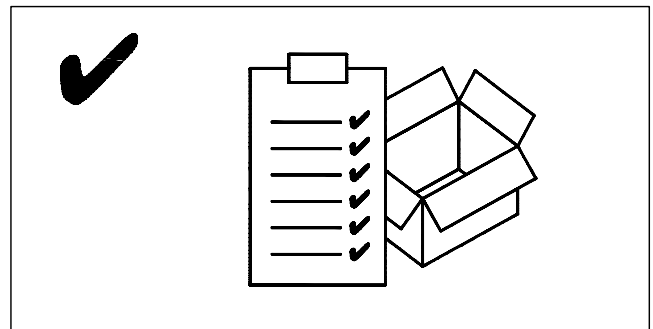
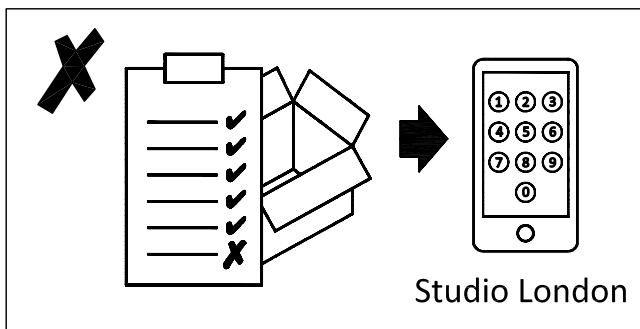

# Your Sideboard

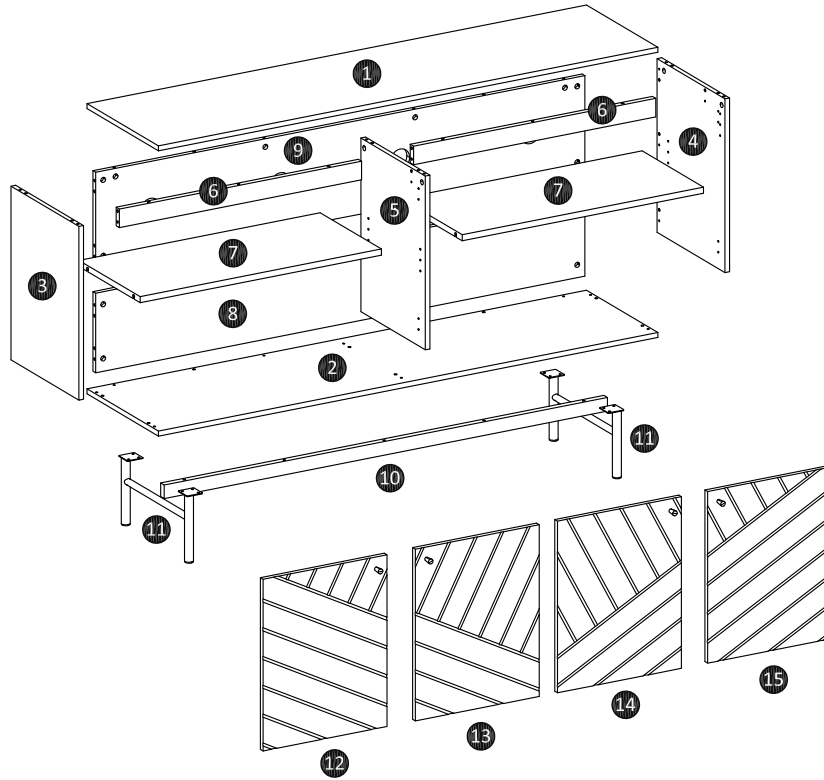





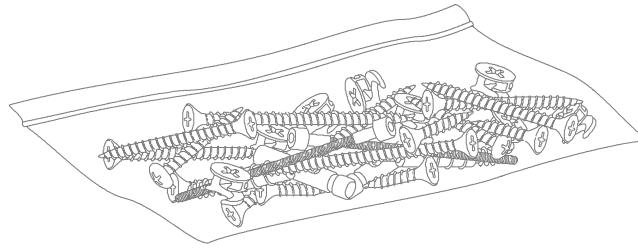

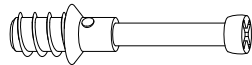
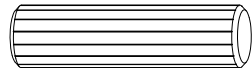

Ref	Description	Dimensions	Qty
①	Top panel	63" x 15.6" x 0.6"	1
②	Bottom panel	63" x 15.6" x 0.6"	1
③	Left panel	20.2" x 14.8" x 0.6"	1
④	Right panel	20.2" x 14.8" x 0.6"	1
⑤	Divider panel	20.2" x 14" x 0.6"	1
⑥	Top support	30.6" x 2.2" x 0.7"	2
⑦	Adjustable shelf	30.5" x 13.4" x 0.7"	2
⑧	Bottom rear panel	61.7" x 9.2" x 0.6"	1
⑨	Top rear panel	61.7" x 11" x 0.6"	1
⑩	Metal support	56" x 1.6" x 0.8"	1
⑪	Metal leg	15" x 2" x 8"	2
⑫	Left door	20" x 15.6" x 0.6"	1
⑬	Middle left door	20" x 15.6" x 0.6"	1
⑭	Middle right door	20" x 15.6" x 0.6"	1
⑮	Right door	20" x 15.6" x 0.6"	1

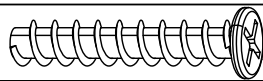

# Fixtures and fittings

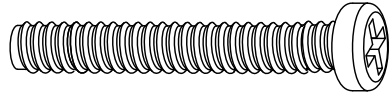





## Fixtures and fittings Supplied (true to size)

Ref	Description	Dimensions	Qty	mm 10 20 30 40 50 60 70 80 90
<b>A</b>	Cam-fix	Dia.15mm	24	
<b>B</b>	Cam-bolt	M7.5 x 32mm	24	
<b>C</b>	Plastic dowel	M8 x 32mm	36	
<b>D</b>	Cam-Sticker	Dia.20mm	24	
<b>E</b>	screw	M4 x 10mm	28	
<b>F</b>	screw	M10 x 33.5mm	10	
<b>G</b>	screw	M6 x 10mm	2	
<b>H</b>	screw	M4 x 20mm	4	
<b>I</b>	Shelf holder	M5 x 7.5mm	8	
<b>J</b>	screw	M6 x 50mm	5	
<b>K</b>	Washer	Dia.6mm	5	

## Fixtures and fittings Supplied (not to scale)

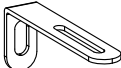
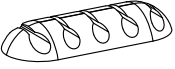
Ref	Description	Dimensions	Qty	
<b>L</b>	Door stopper	N/A	4	
<b>M</b>	Curve hinge	N/A	4	

Ref	Description	Dimensions	Qty	
N	Straight Hinge	N/A	4	
O	Cable holder	N/A	4	
P	Shelf support	N/A	8	
Q	Wall bracket	N/A	2	
R	Cable clamp	N/A	2	
S	Handle	N/A	4	

# Product assembly

Amara Sideboard - Oak Finish  
SLAMASBMEL02

## Step 1

Parts, fittings and tools

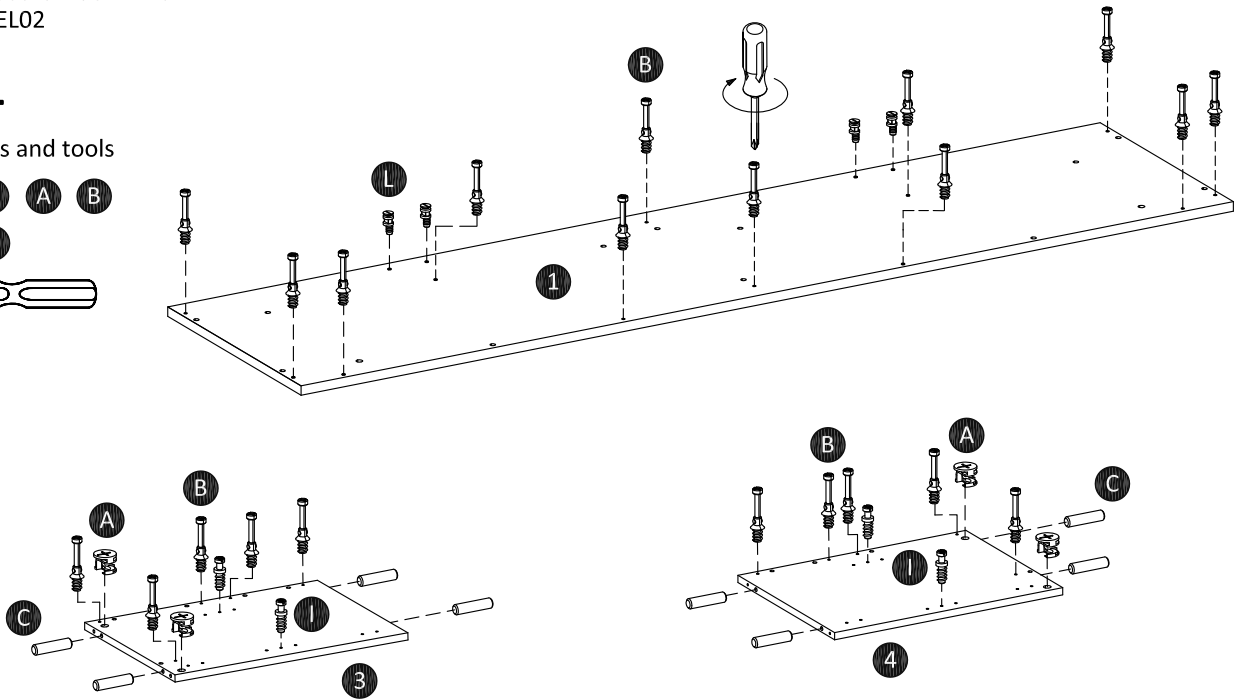
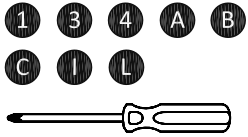

Attach cam-bolt (B) to top panel (1), left panel (3) and right panel (4) using screwdriver.  
Attach Shelf holder (I) to left panel (3) and right panel (4).  
Insert door stopper (L) into top panel (1) also cam-fix (A) and plastic dowel (C) into left panel (3) and right panel (4).

## Step 2

Parts, fittings and tools

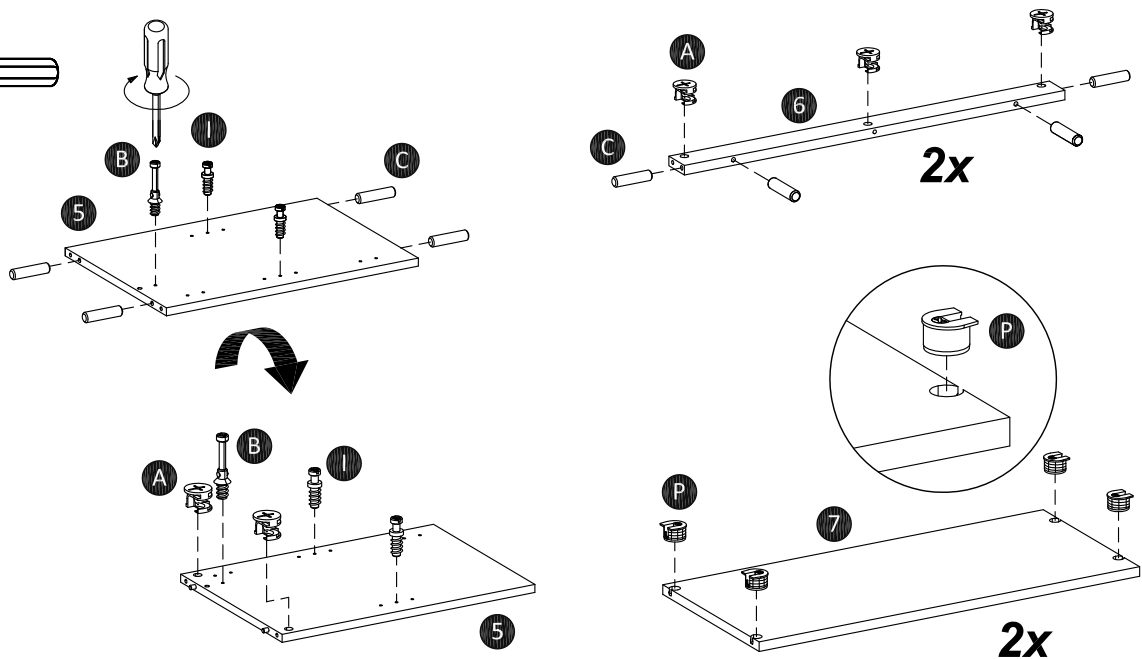
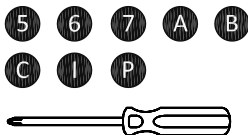

Attach cam-bolt (B) to divider panel (5) using screwdriver.  
Insert shelf holder (I) to divider panel (5) as shown.  
Insert cam-fix (A) and plastic dowel (C) into divider panel (5) and top support (6).  
Insert shelf support (P) into adjustable shelf (7) as shown.

# Product assembly

Amara Sideboard - Oak Finish  
SLAMASBMEL02

## Step 3

Parts, fittings and tools

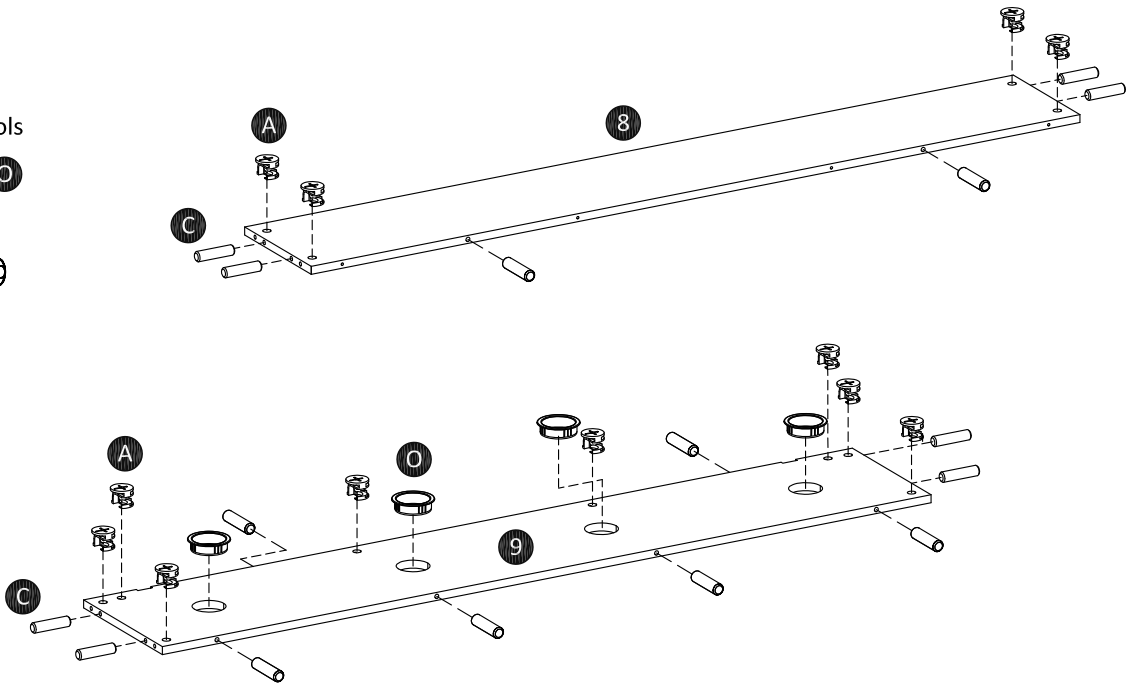
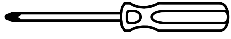

Insert cam-fix (A) and plastic dowel (C) into bottom rear panel (8) and top rear panel (9).  
Insert cable holder (O) into top rear panel (9) as shown.

## Step 4

Parts, fittings and tools

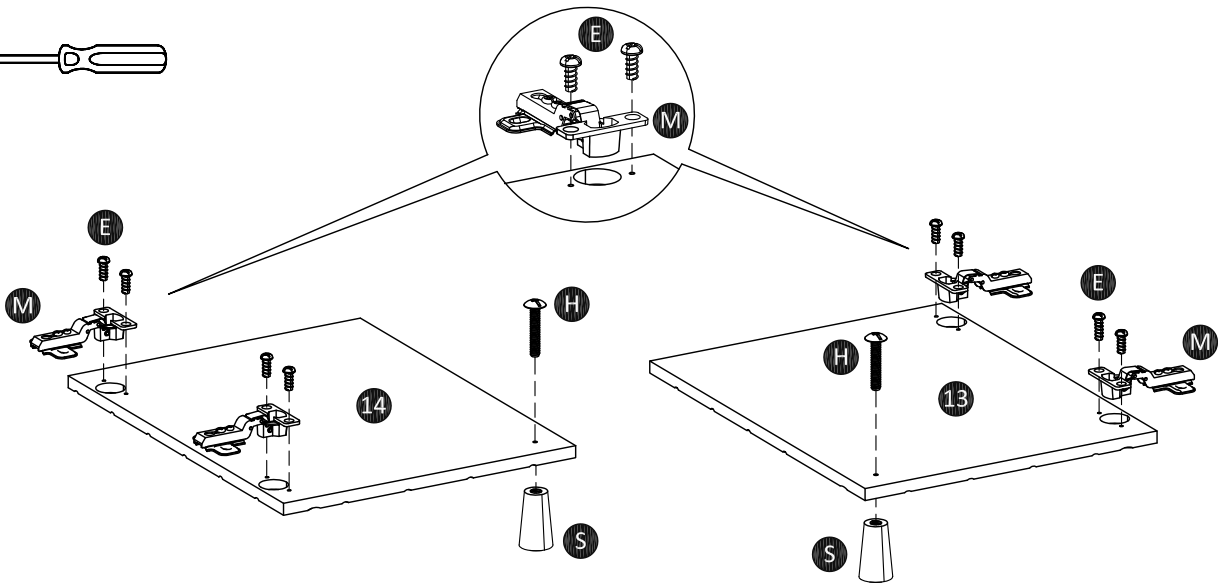
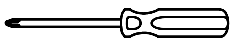

Attach curve hinge (M) using screw (E) and handle (S) using screw (H) to middle left door (13) also middle right door (14).



# Product assembly

Amara Sideboard - Oak Finish  
SLAMASBMEL02

## Step 5

Parts, fittings and tools

12 15 E H N S

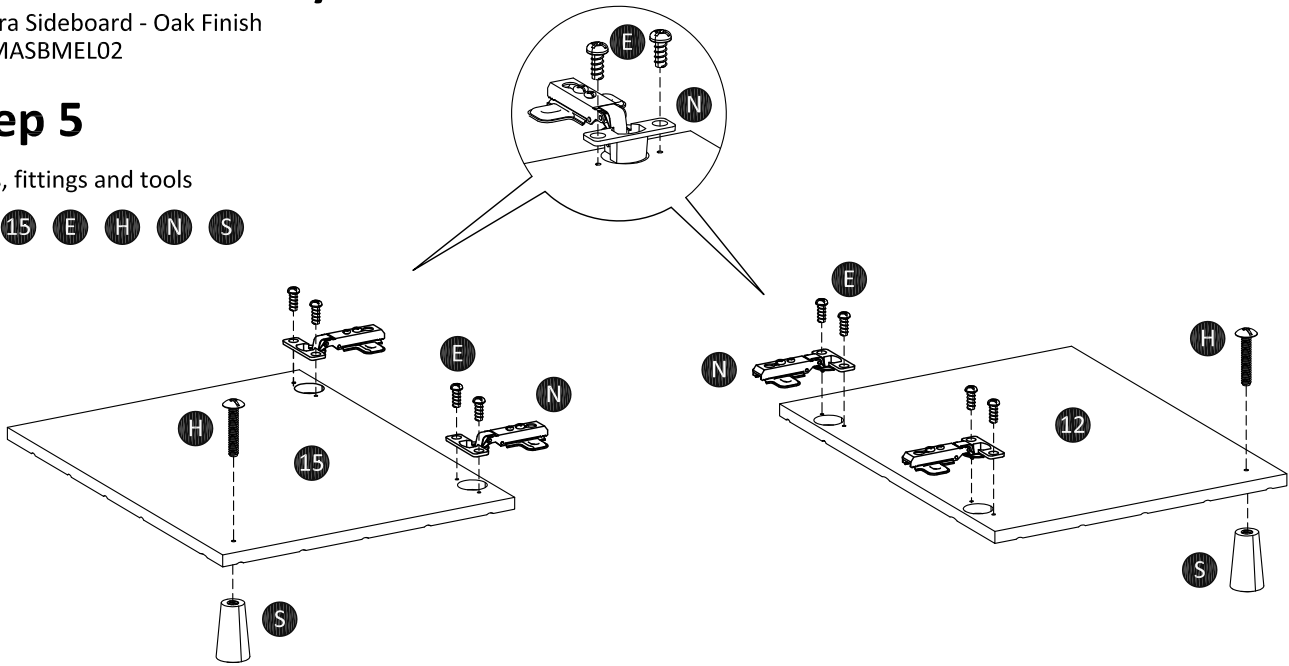

Attach strike hinge (N) using screw (E) and handle (S) using screw (H) to left door (12) also right door (15).

## Step 6

Parts, fittings and tools

3 5 6 8 9

A D

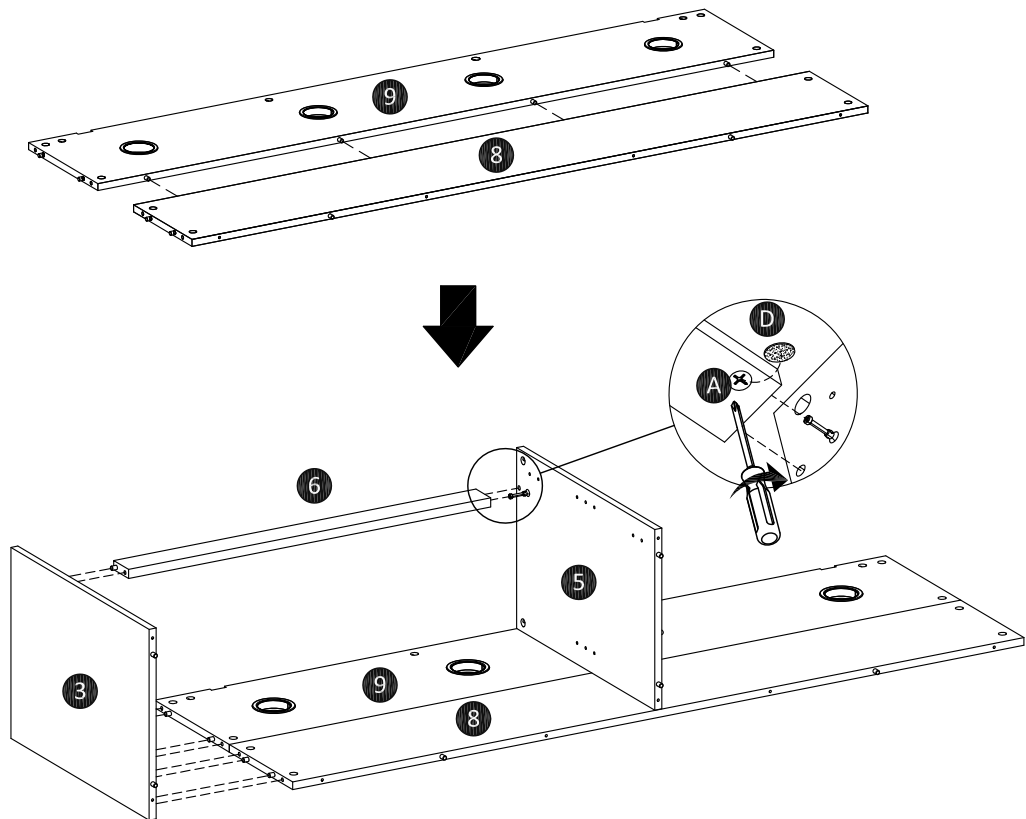
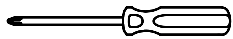

Install bottom rear panel (8) with top rear panel (9) as shown.

Attach top support (6) between left panel (3) and divider panel (5), install them on the left side of rear panel as shown.

Turn the cam-lock (A) clockwise to lock using screwdriver, then paste cam-sticker (D).

# Product assembly

Amara Sideboard - Oak Finish  
SLAMASBMEL02

## Step 7

Parts, fittings and tools

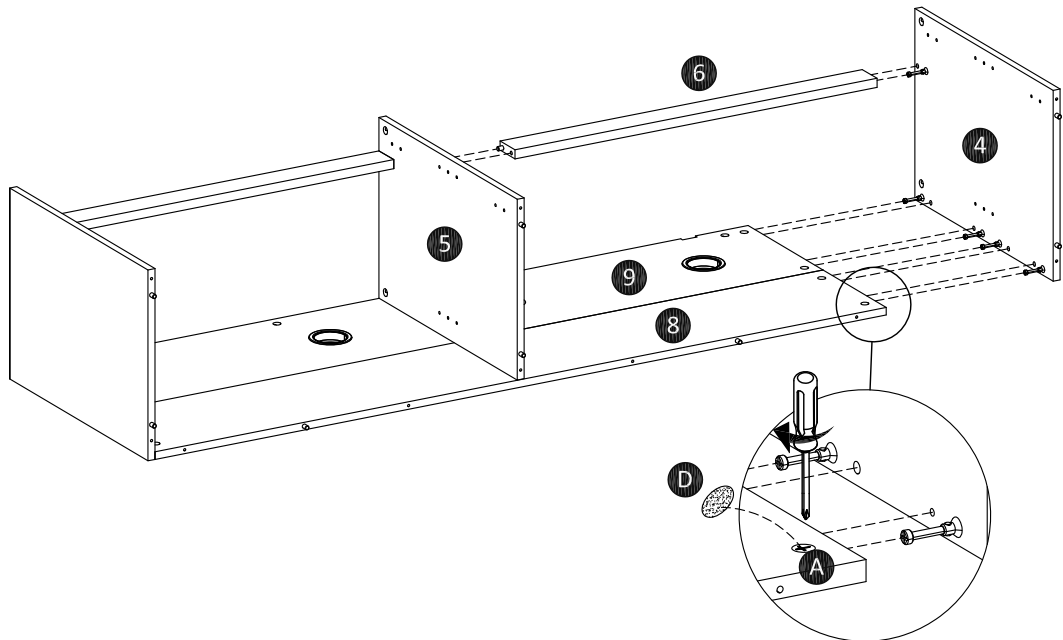
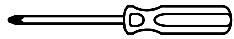

Attach top support (6) between right panel (4) and divider panel (5), install them on the right side of rear panel as shown. Turn the cam-lock (A) clockwise to lock using screwdriver, then paste cam-sticker (D).

## Step 8

Parts, fittings and tools

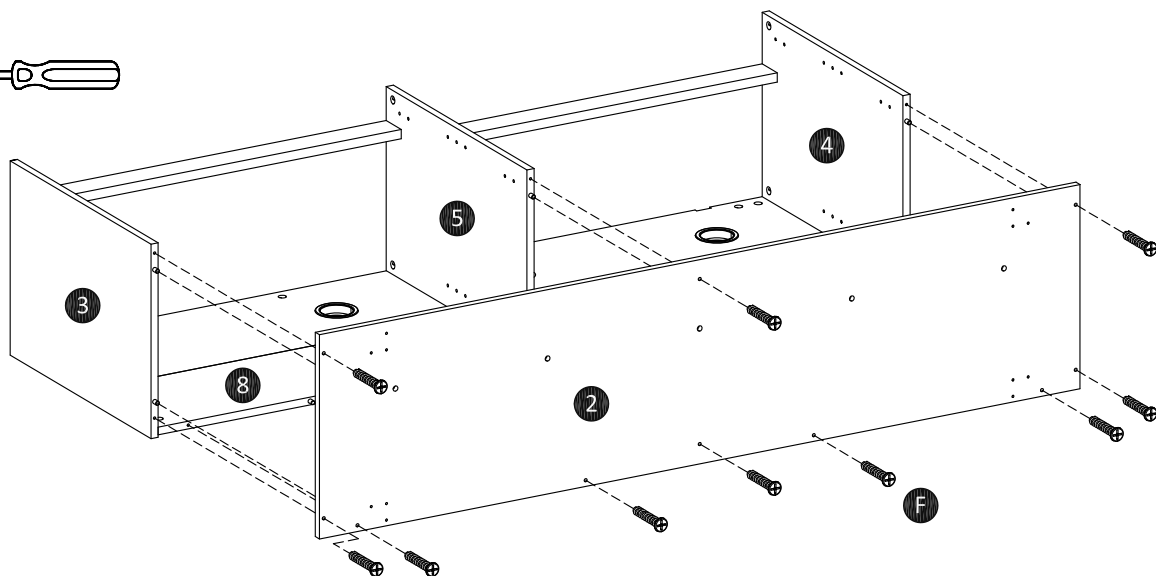
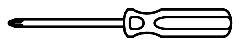

Attach bottom panel (2) to case assembly using screw (F).

# Product assembly

Amara Sideboard - Oak Finish  
SLAMASBMEL02

## Step 9

Parts, fittings and tools

2 10 J K

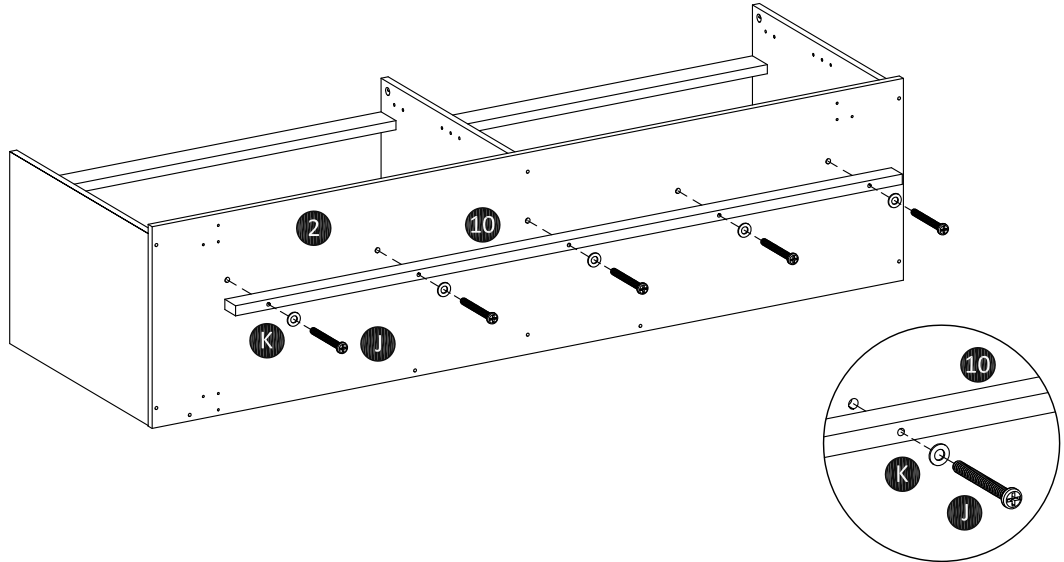
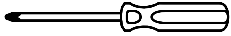

Attach metal support (10) to bottom panel (2) using screw (J) and washer (K).

## Step 10

Parts, fittings and tools

2 11 E

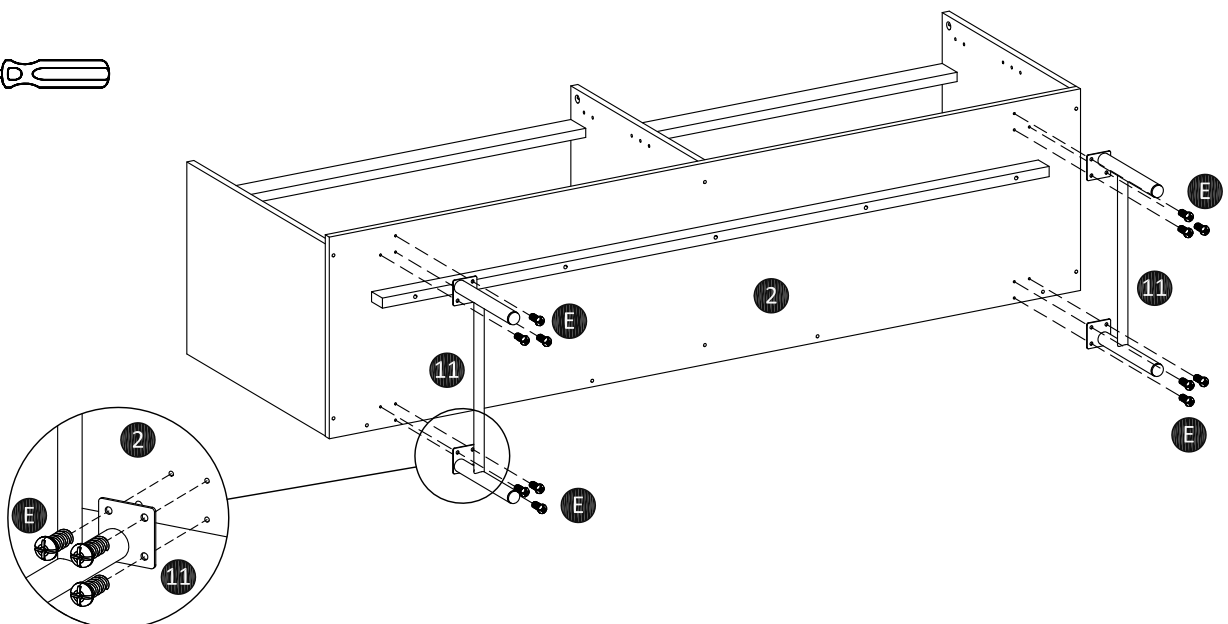
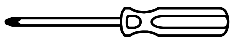

Attach metal leg (11) to bottom panel (2) using screw (E).

# Product assembly

Amara Sideboard - Oak Finish  
SLAMASBMEL02

## Step 11

Parts, fittings and tools

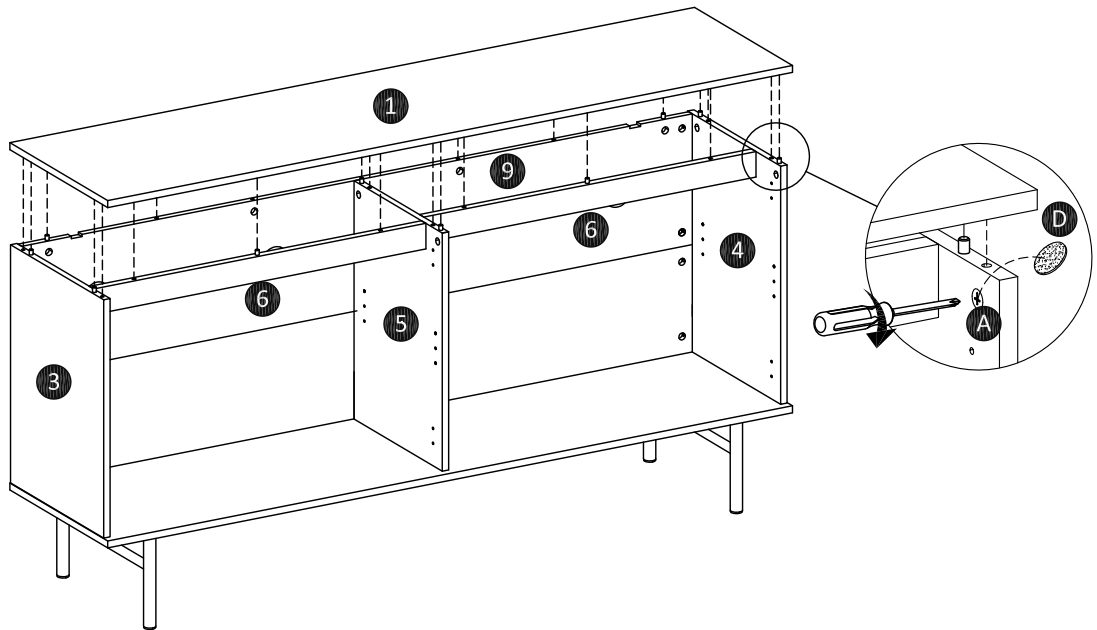
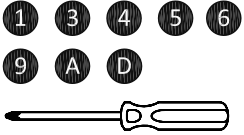

Attach top panel (1) to case assembly as shown.  
Turn the cam-lock (A) clockwise to lock using screwdriver, then paste cam-sticker (D).

## Step 12

Parts, fittings and tools

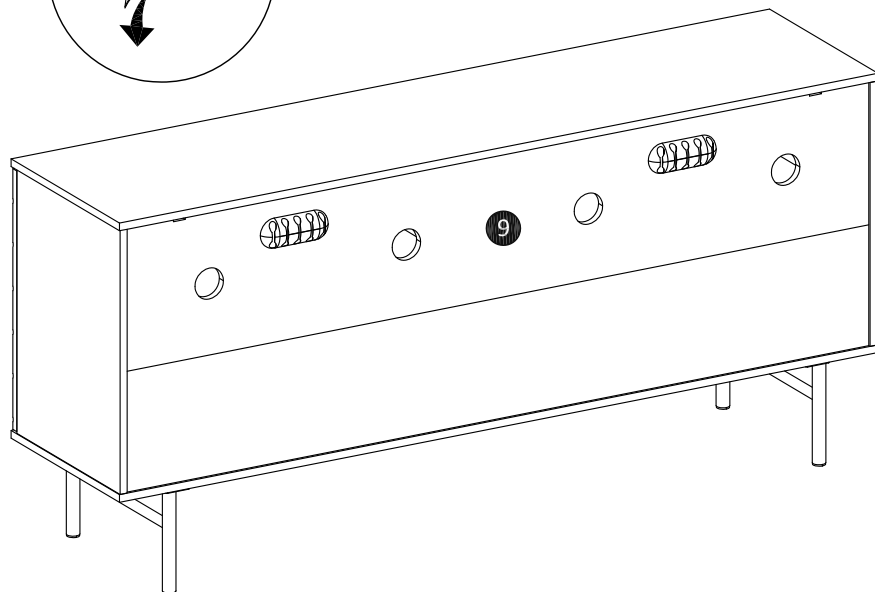
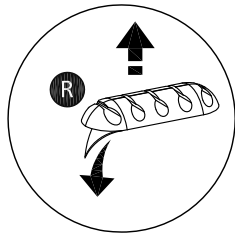

Attach cable clamp (R) on the back of top rear drawer (9) as shown.

# Product assembly

Amara Sideboard - Oak Finish  
SLAMASBMEL02

View from inside the cabinet.

## Step 13

Parts, fittings and tools

1 G Q

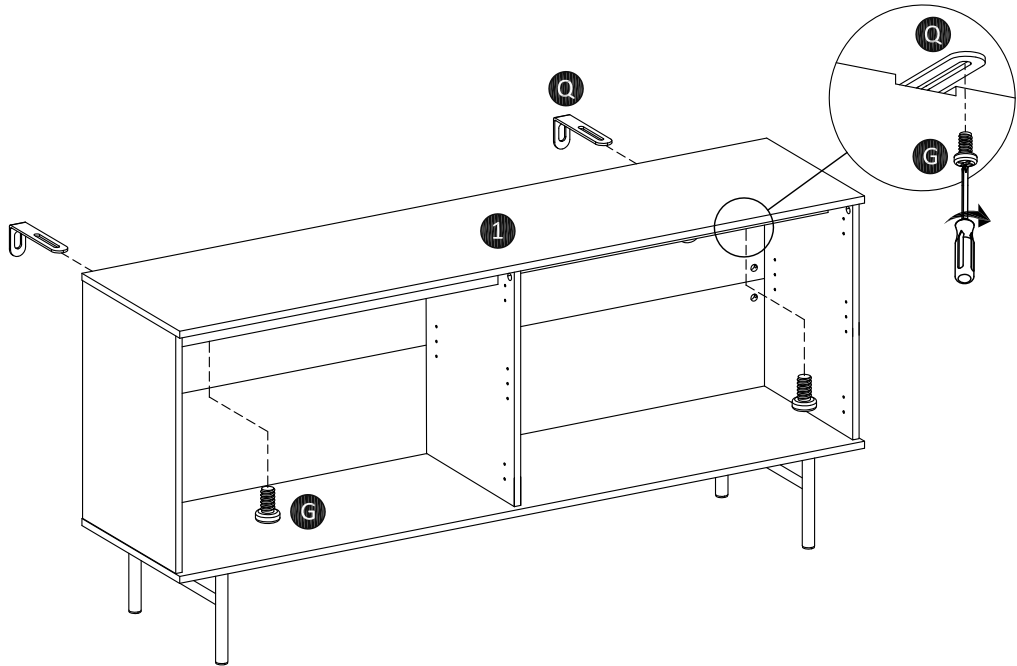
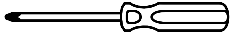

Locate wall brackets (Q) in the slots of case assembly, then fasten to the inside of case assembly with screw (G) using screwdriver.

## Step 14

Parts, fittings and tools

3 4 5 7

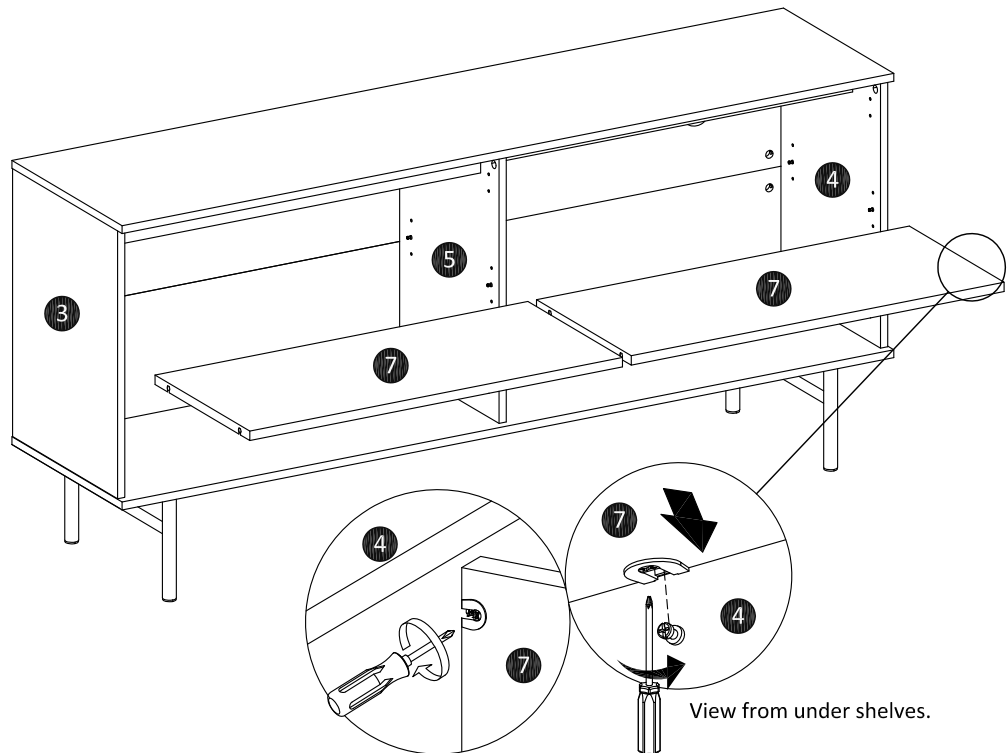
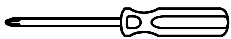

Insert adjustable shelf (7) into case assembly as shown.  
Turn the shelf support (P) clockwise to lock using screwdriver as shown.

# Product assembly

Amara Sideboard - Oak Finish  
SLAMASBMEL02

## Step 15

Parts, fittings and tools

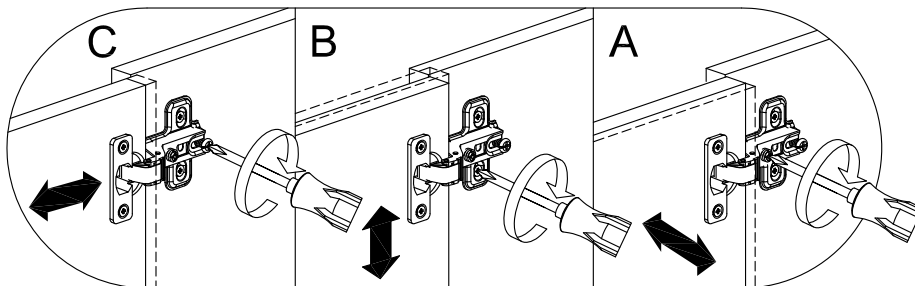
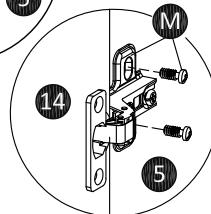
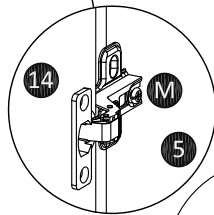
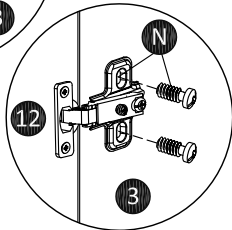
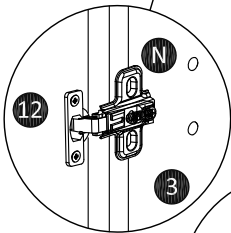
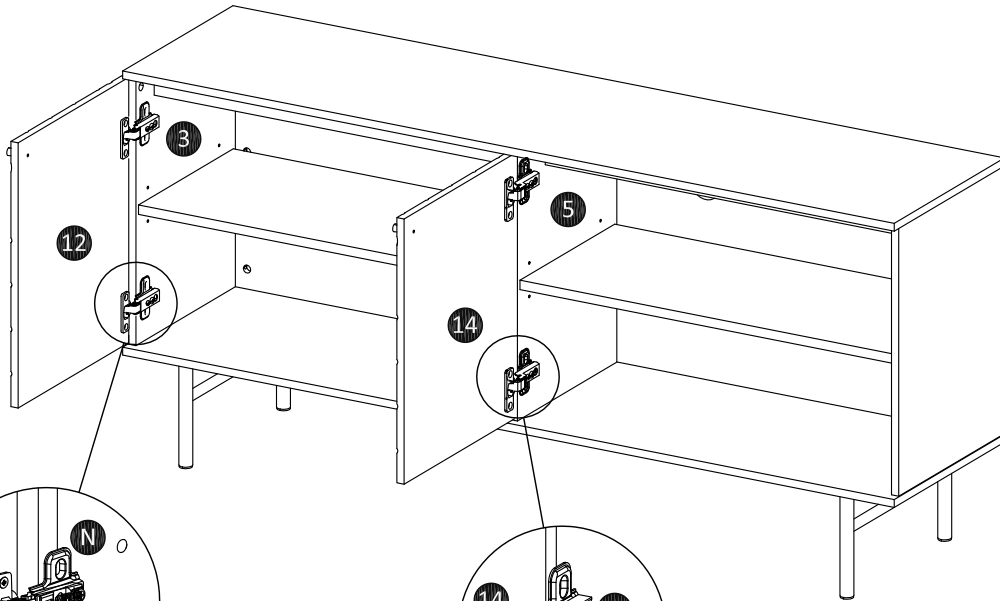
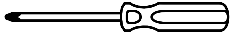

Attach left door (12) to left panel (3) then tightening the screw using screwdriver.  
Attach middle right door (14) to divider panel (5) then tightening the screw using screwdriver.  
Adjust the hinge on the door until fix with the assembly.

# Product assembly

Amara Sideboard - Oak Finish  
SLAMASBMEL02

## Step 16

Parts, fittings and tools

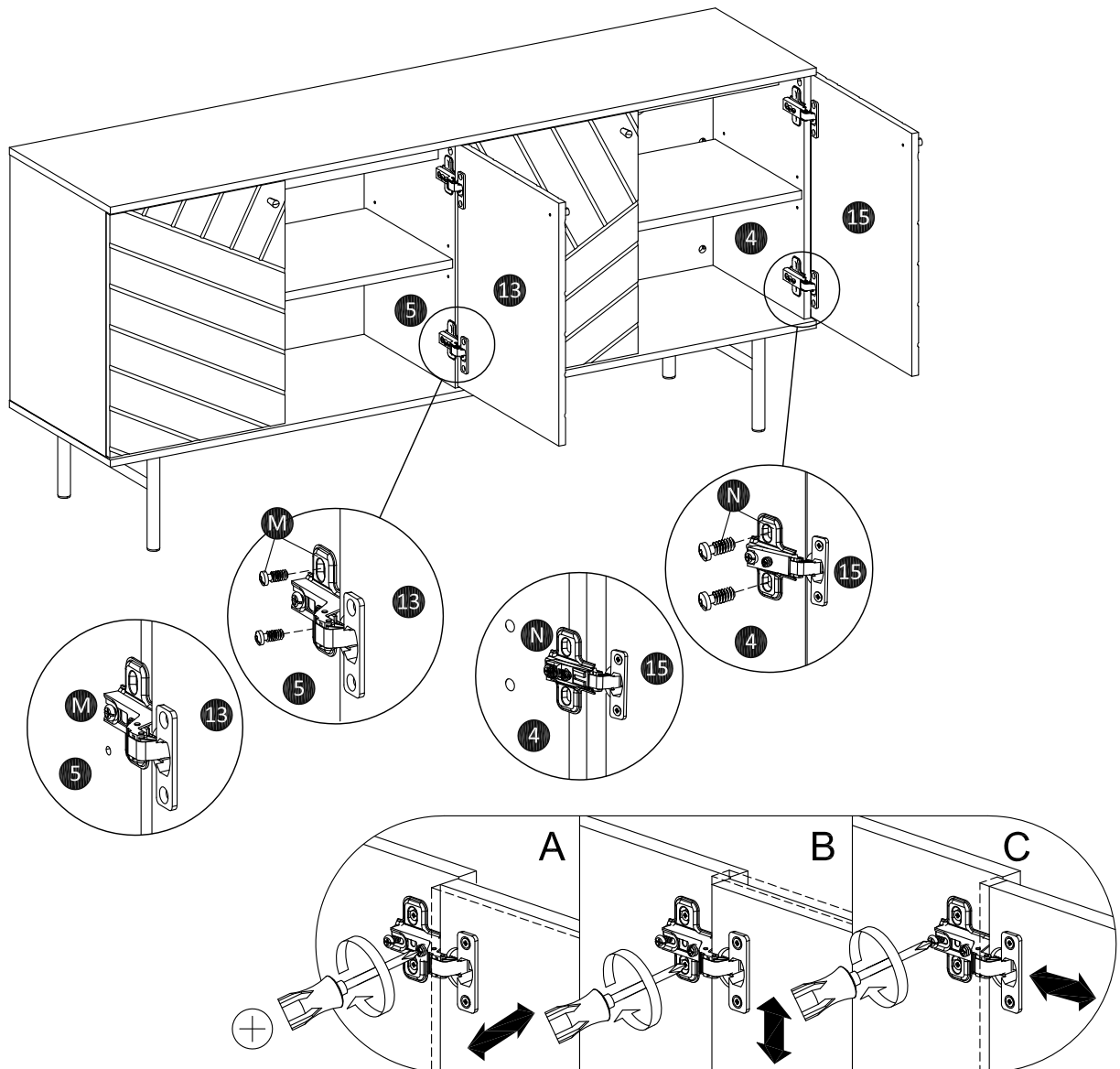
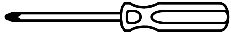

Attach middle left door (13) to divider panel (5) then tightening the screw using screwdriver.  
Attach right door (15) to right panel (4) then tightening the screw using screwdriver.  
Adjust the hinge on the door until fix with the assembly.

# Product assembly

Amara Sideboard - Oak Finish  
SLAMASBMEL02

## Step 17

Parts, fittings and tools

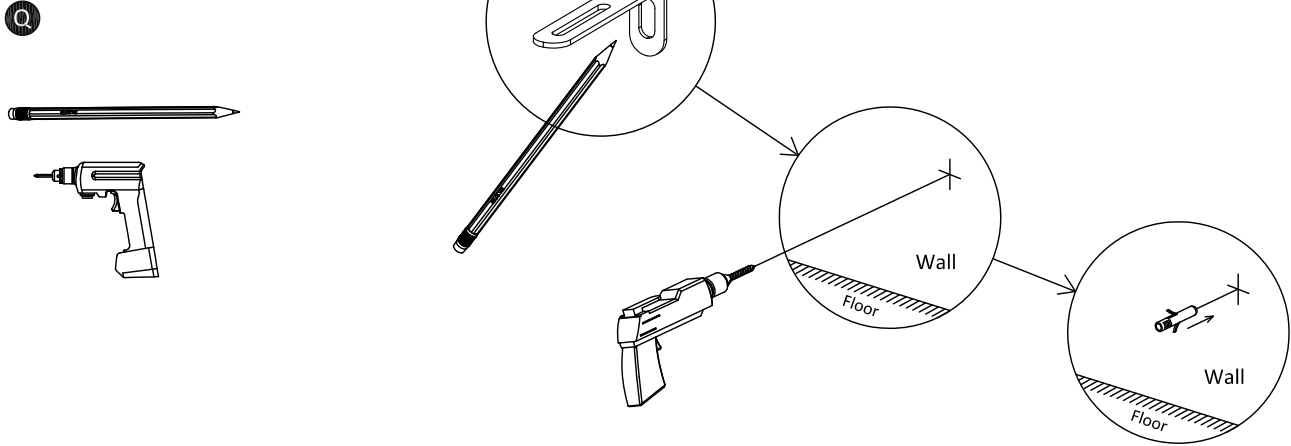

Reposition the wall bracket with a pencil where the screw holes are going to be located. Before drilling, ensure the size of holes will be correct to fit the rawl plugs (not included).

Warning: Ensure the area to be drilled is free from hidden electrical wires, water and gas pipes.

Caution: The wall fixings supplied are for solid brick walls only.

Drill the holes according to the marked position. Push the rawl plugs (not included) into position as shown above.

## Step 18

Parts, fittings and tools

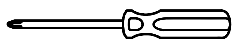

Secure the wall brackets (Q) to the wall using the washers (K) and screws (not included). Tighten with the screwdriver.



# Product assembly

Amara Sideboard - Oak Finish  
SLAMASBMEL02



## Care and maintenance

### Wood furniture

Wood displays different grain patterns depending on which way they are cut - for example, the 'medullary ray' which can appear on oak furniture is a mark of good quality timber - these are just characteristics of natural beauty of the wood. Some furniture is also deliberately aged and rustic, wood veneers also allow a distinctive pattern to be created on some surface, such as tabletops and drawer fronts by the way slivers are arranged.

### How to care for your wood furniture

Furniture with a hard lacquer, wax polish or painted surface should be dusted with a dry cloth. Waxed furniture will need to be given a coat of beeswax a couple of times a year to help maintain its lustre.

Spray polishes are best avoided as they contain silicones which may spoil the furniture's surface when building up over time.

Make sure all surfaces are protected from the heat and liquids by mats and coasters. Wipe up spills immediately and ensure that a mat or pad is placed under paper if you are writing.

Our furniture will endure most temperatures in the home, but it is best to avoid placing furniture next to heat sources such as radiators or fires. Be particularly careful with solid wood as the lack of humidity caused by home heating can cause damage such as warping.

### Caution

This wood has a painted surface that can scratch. Please avoid contact with hard, sharp objects. Avoid placing plant pots or vases without waterproof mats to prolong the life of the product.

**Please do not sit or lean on this product.**

**Maximum Load Capacity:** 93 lbs for the top surface, 66 lbs for each shelf.

Retain these instructions for furniture reference.

**Your feedback is very important to us and we would love to hear your comments on your new furniture. Please visit our website to leave a review. Thank you.**

## Safe Home - Furniture

At Studio London we pride ourselves in developing product that is great quality, offering the best possible value for money.

We also care about your safety, engineering product to minimise any potential risk and providing you with information to enable you to make your home safe and prevent accidents from happening.

### Furniture stability

Furniture stability and 'tipping or overturning' is of particular concern and it's important to consider the environment in which your furniture is being placed and who might come in to contact with it. For example small children may be attracted to toys placed out of reach and may use furniture as a ladder to retrieve them. The elderly may also use furniture to pull themselves up from low seating and even pets climbing on furniture could cause furniture to become unstable.

It's also recommended that heavy item such as TVs are positioned on furniture suitable for the job to prevent any risk of the furniture toppling over.

Other considerations to prevent accidents are how furniture is loaded. Heavier items should be positioned on lower shelves or lower drawers so that the furniture is more stable and less likely to topple.

### Wall fixing or attachment devices

We would strongly recommend that all freestanding furniture 23 5/8 inch in height is attached to the wall for added safety. This is critical where babies and children have access and there is an increased risk of a toppling incident occurring.

Consider the type of wall that your furniture is to be positioned against when making your purchase and make sure that you use the correct wall fixings referring to the 'wall anchoring guide' which you will find in your product instructions.

If in doubt about which wall fixings to use, or if you're concerned about your DIY competency seek expert advice from a qualified tradesperson.

### Warning label

The following label can be found on own brand products and is affixed permanently. This should remain on the product for the duration of its life additionally offering guidance to costumers that purchase the furniture in the second hand market.

