

**Studio
London.**

Amara Media Unit - Oak Finish
Stock number: SLAMATVMEL02

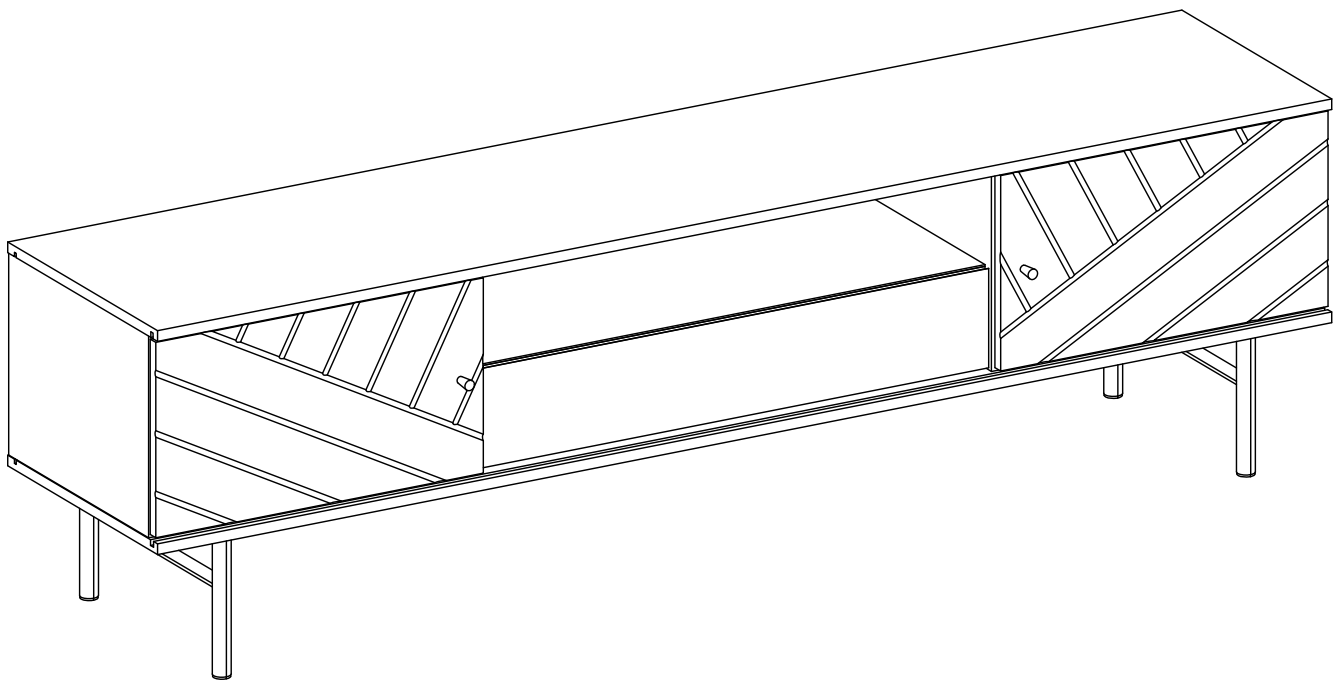

70.5"W x 15.6"D x 20.3"H

Congratulations on your purchase from Studio London!

In buying one of our quality products, you now own an item we sincerely hope you will love for years to come, without it coating the earth.

Responsibility is one of our core brand values. For every item sold, a tree is planted. Additionally, we invest in carbon reducing schemes, ensure all our materials are sustainable and responsibly sourced, and audit our suppliers to ensure they are safe, supportive and ethically sound.

We hope you love your item. We would love to hear any feedback or comment.

Visit us at www.studiolondon.net to comment or to find out more, and please follow us on instagram at [studio_london_design](https://www.instagram.com/studio_london_design).

Tools required

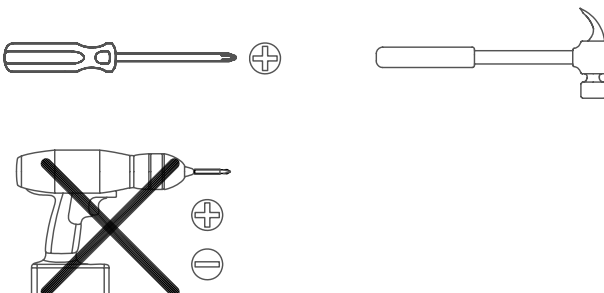

Don't use an electric screwdriver to assemble the cabinet panels.

Time to assemble
45 mins

People to assemble

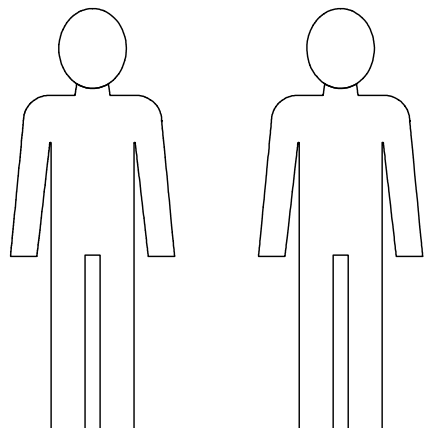

Important safety information

Warnings

- ⚠ **This product is not suitable for bedrooms.**
- ⚠ The product should only be used on firm, level ground.
- ⚠ Keep small parts out of reach of children.
- ⚠ Ensure the product is fully assembled as illustrated before use.

Do's

- ✓ Check the pack and make sure you have all the parts listed.
- ✓ Check all screws or bolts are tightened and inspect regularly.
- ✓ Make sure the legs remain in contact with the ground all time.

Don't

- ✗ Do not over tighten screws or bolts.
- ✗ Do not stand on the product.
- ✗ Do not use power tools to construct as overtightening and panel failure may occur.

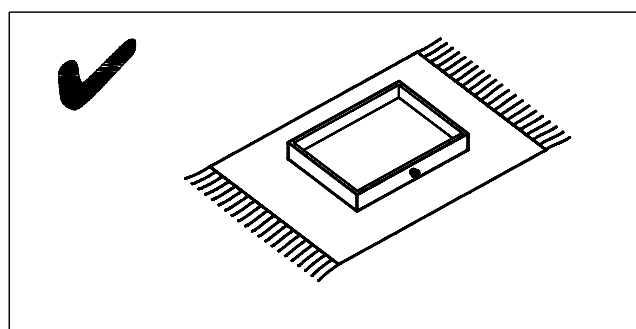
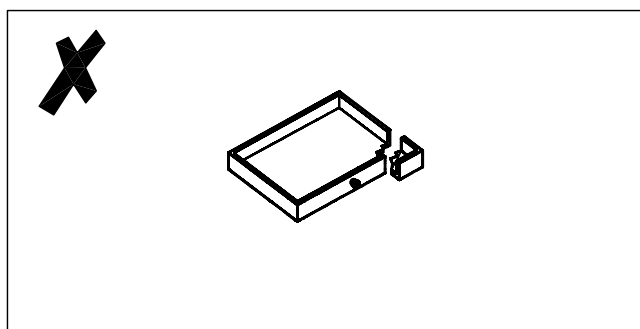
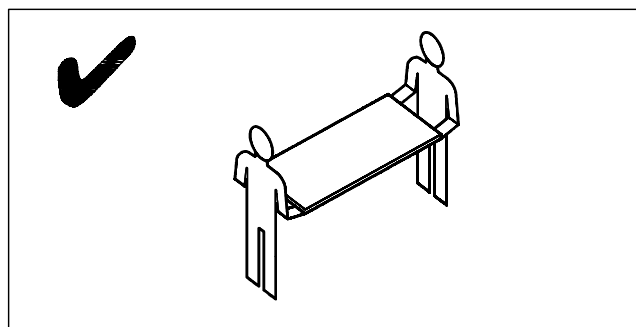
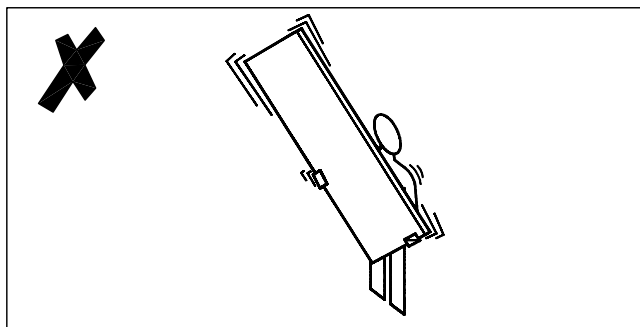
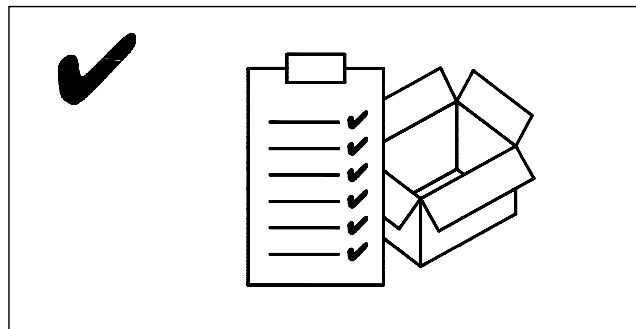
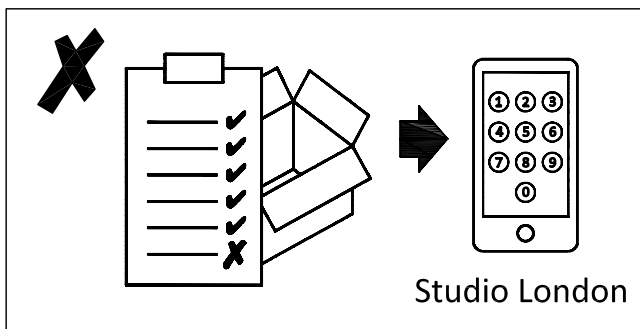

Your TV Stand

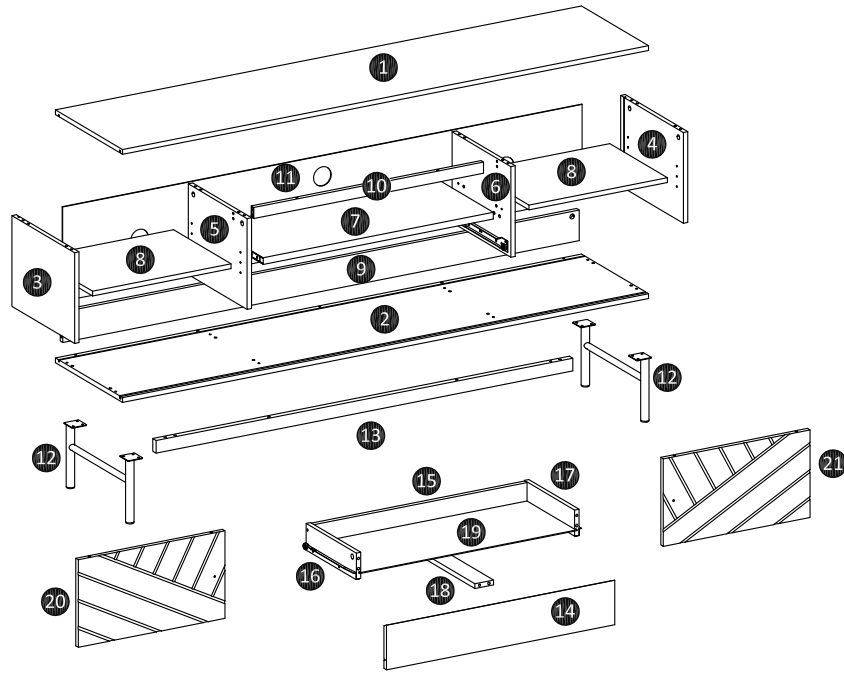





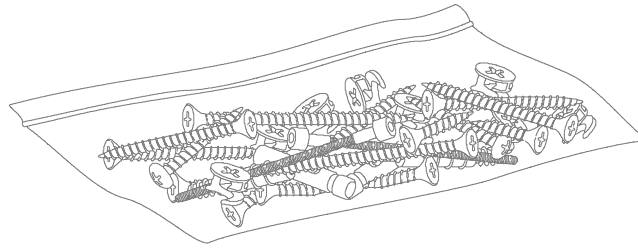



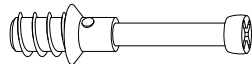
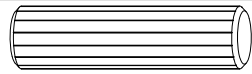
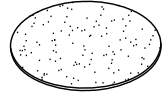

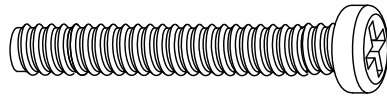

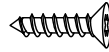
Ref	Description	Dimensions	Qty
①	Top panel	70.6" x 15.6" x 0.6"	1
②	Bottom panel	70.6" x 15.6" x 0.6"	1
③	Left panel	11.2" x 14.6" x 0.6"	1
④	Right panel	11.2" x 14.6" x 0.6"	1
⑤	Left divider	11.2" x 13.5" x 0.6"	1
⑥	Right divider	11.2" x 13.5" x 0.6"	1
⑦	Fix shelf	30.9" x 12.9" x 0.8"	1
⑧	Adjustable shelf	18.5" x 13.4" x 0.6"	2
⑨	Rear panel	69.3" x 3.8" x 0.6"	1
⑩	Top metal support	30.8" x 1.4" x 0.6"	1
⑪	Backboard	69.7" x 11.6" x 0.09"	1
⑫	Metal leg	15" x 2" x 7.9"	2
⑬	Bottom metal support	58.9" x 1.6" x 0.8"	1
⑭	Front drawer	30.6" x 5.5" x 0.6"	1
⑮	Rear drawer	28.7" x 3.1" x 0.6"	1
⑯	Left drawer	11.6" x 3.2" x 0.6"	1
⑰	Right drawer	11.6" x 3.2" x 0.6"	1
⑱	Bottom support drawer	11" x 2.5" x 0.6"	1
⑲	Bottom drawer	29.1" x 11.5" x 0.09"	1
⑳	Left door	10.8" x 19.7" x 0.6"	1
㉑	right door	10.8" x 19.7" x 0.6"	1

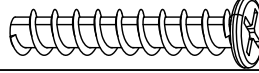
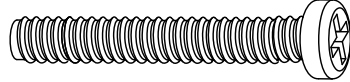
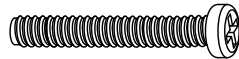

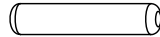

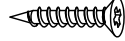

Fixtures and fittings



Fixtures and fittings Supplied (true to size)

Ref	Description	Dimensions	Qty	mm 10 20 30 40 50 60 70 80 90
A	Cam-fix	Dia.15mm	17	
B	Cam-bolt	M7.5 x 32mm	17	
C	Plastic dowel	M8 x 32mm	30	
D	Cam-Sticker	Dia.20mm	17	
E	screw	M3 x 12mm	2	
F	screw	M6 x 50mm	6	
G	screw	M4 x 10mm	12	
H	screw	M6 x 13mm	4	
I	screw	M6 x 8mm	4	
J	screw	M10 x 33.5mm	14	
K	screw	M6 x 45mm	2	
L	screw	M6 x 30mm	4	
M	screw	M4 x 19mm	8	
N	Door stopper	M5 x 20mm	2	
O	screw	M4 x 20mm	2	
P	screw	M6 x 15mm	4	
Q	Washer	Dia.6mm	8	

**Fixtures and fittings
Supplied (not to scale)**

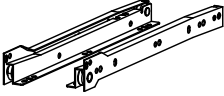
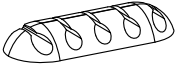
Ref	Description	Dimensions	Qty	
R	Fix pin	N/A	4	
S	Push pin	N/A	4	
T	Handle	N/A	2	
U	Drawer stopper	N/A	2	
V	Shelf support	N/A	8	
W	Backply stopper	N/A	8	
X	Drawer Rail	300mm	1	
Y	Cable clamp	N/A	2	

Product assembly

Amara Media Unit - Oak Finish
SLAMATVMEL02

Step 1

Parts, fittings and tools

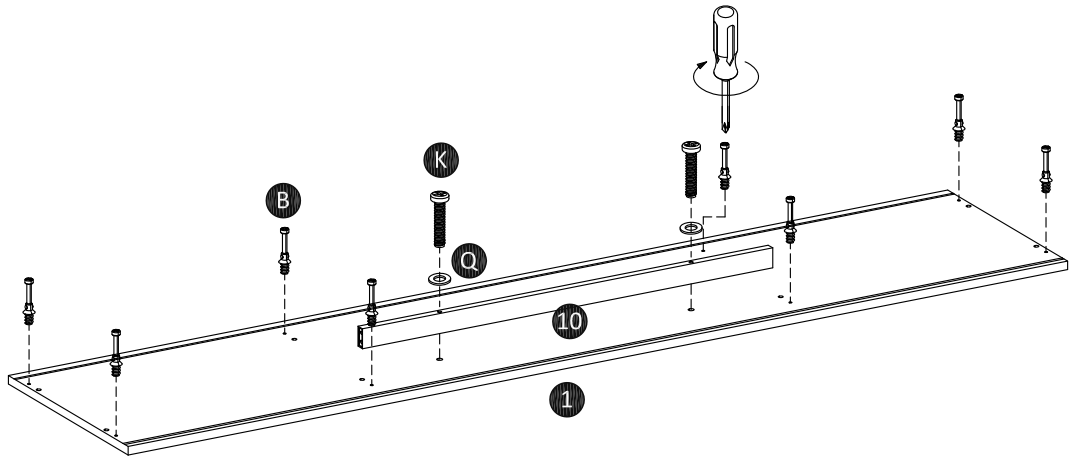
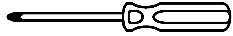

Attach cam-bolt (B) to top panel (1) using screwdriver.
Attach top metal support (10) to top panel (1) using screw (K) and washer (Q).

Step 2

Parts, fittings and tools

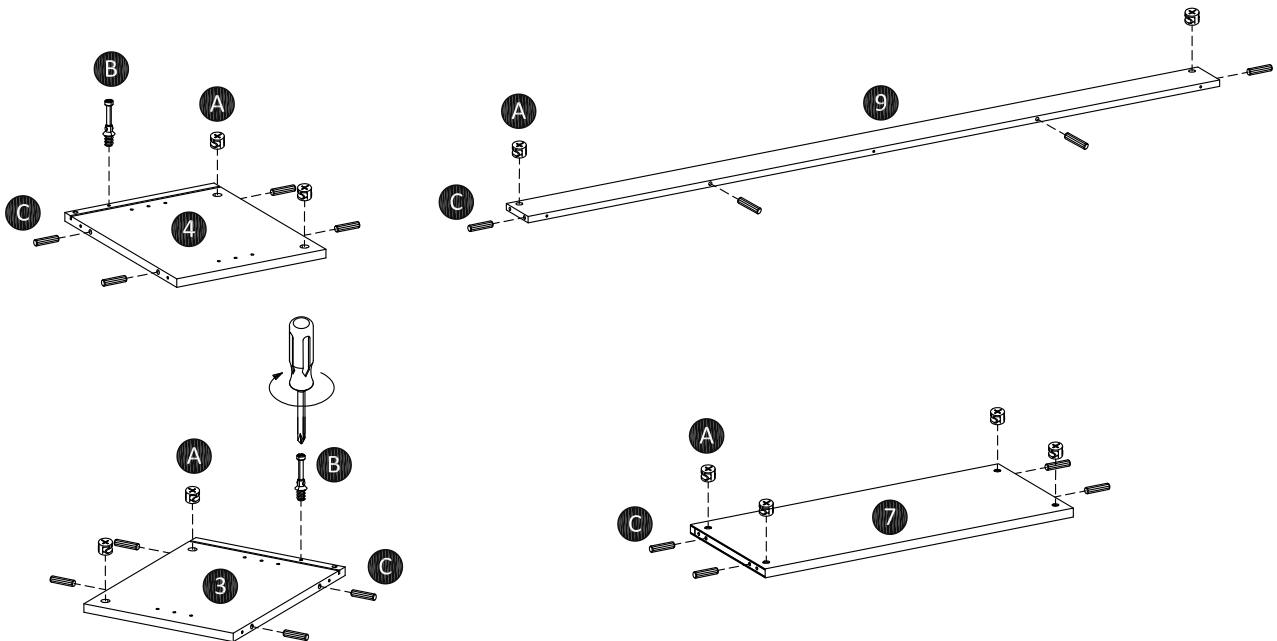
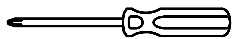

Attach cam-bolt (B) to left panel (3) and right panel (4) using screwdriver.
Insert cam-fix (A) and plastic dowel (C) into left panel (3), right panel (4), fix shelf (7) and rear panel (9).

Product assembly

Amara Media Unit - Oak Finish
SLAMATVMEL02

Step 3

Parts, fittings and tools

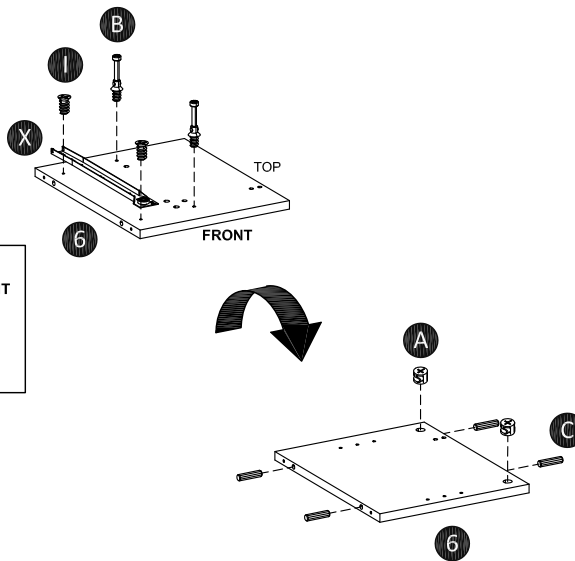
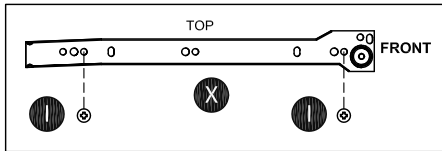
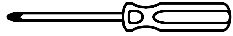

Attach cam-bolt (B) to right divider (6) using screwdriver, then insert cam-fix (A) and plastic dowel (C).
Attach drawer rail (X) to right divider (6) using screw (I).

Step 4

Parts, fittings and tools

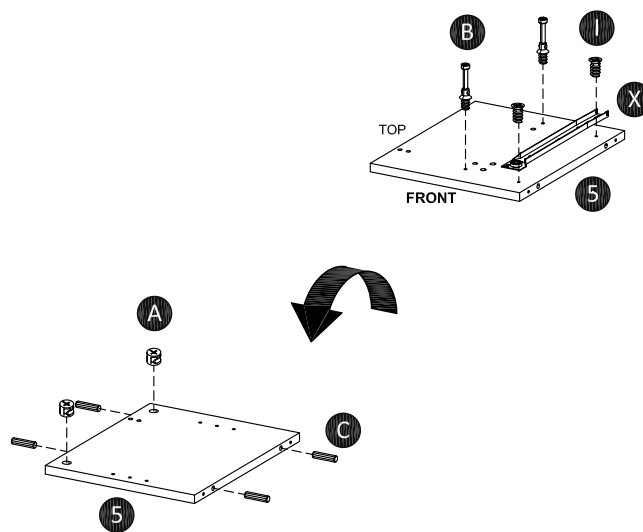
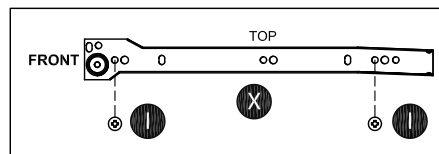
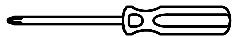

Attach cam-bolt (B) to left divider (5) using screwdriver, then insert cam-fix (A) and plastic dowel (C).
Attach drawer rail (X) to left divider (5) using screw (I).

Product assembly

Amara Media Unit - Oak Finish
SLAMATVMEL02

Step 5

Parts, fittings and tools

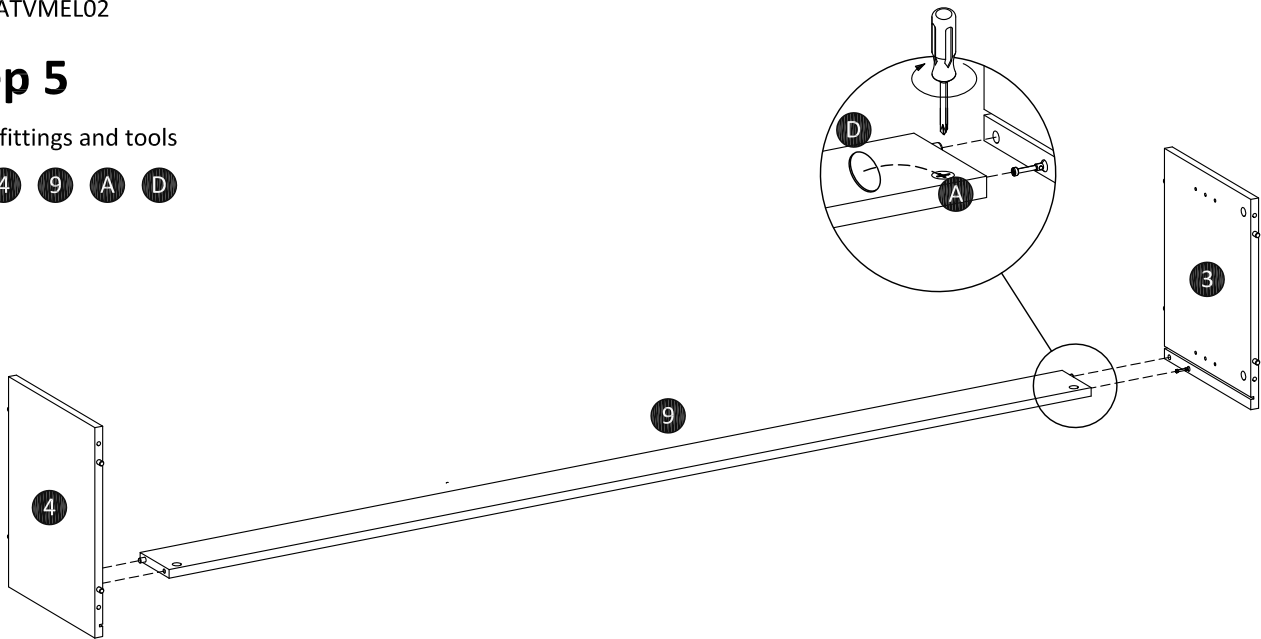

Attach left panel (3) and right panel (4) to rear panel (9) as shown.
Turn the cam-lock (A) clockwise to lock using screwdriver, then paste cam-sticker (D).

Step 6

Parts, fittings and tools

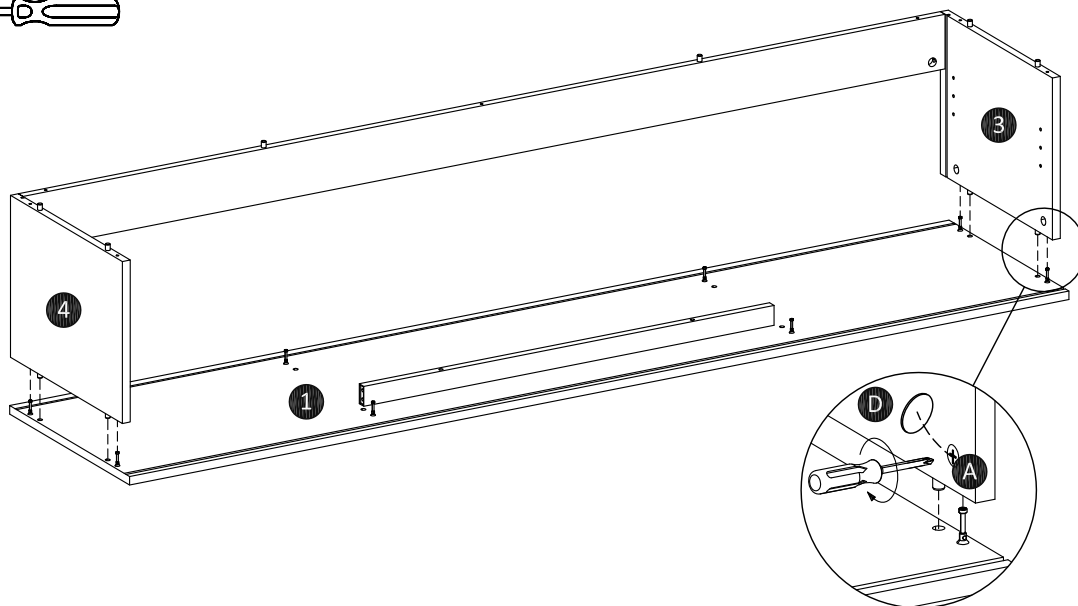
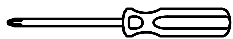

Attach case assembly to top panel (1) as shown.
Turn the cam-lock (A) clockwise to lock using screwdriver, then paste cam-sticker (D).

Product assembly

Amara Media Unit - Oak Finish
SLAMATVMEL02

Step 7

Parts, fittings and tools

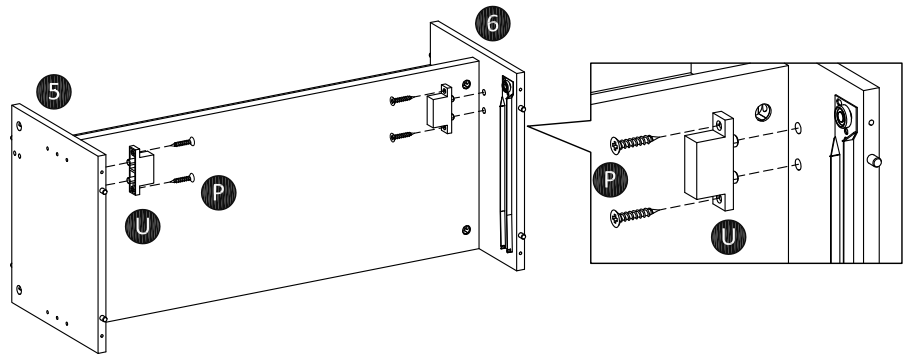
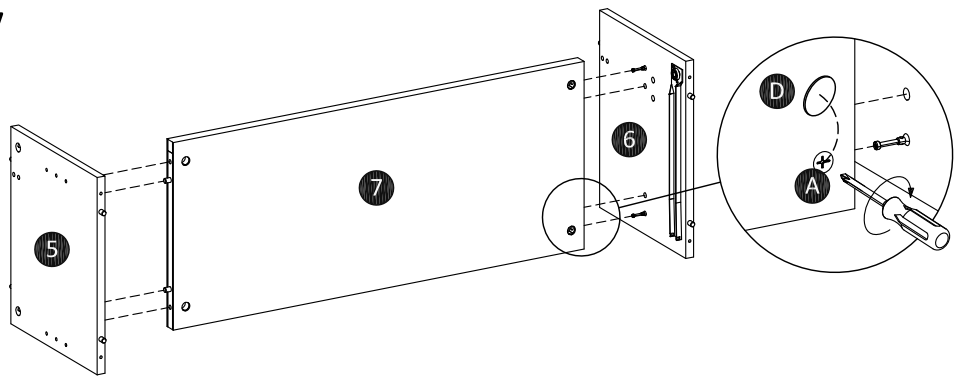
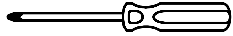

Attach left divider (5) and right divider (6) to fix shelf (7) as shown.
Turn the cam-lock (A) clockwise to lock using screwdriver, then paste cam-sticker (D).
Attach Drawer stopper (U) to left divider (5) and right divider (6) using screw (P).

Step 8

Parts, fittings and tools

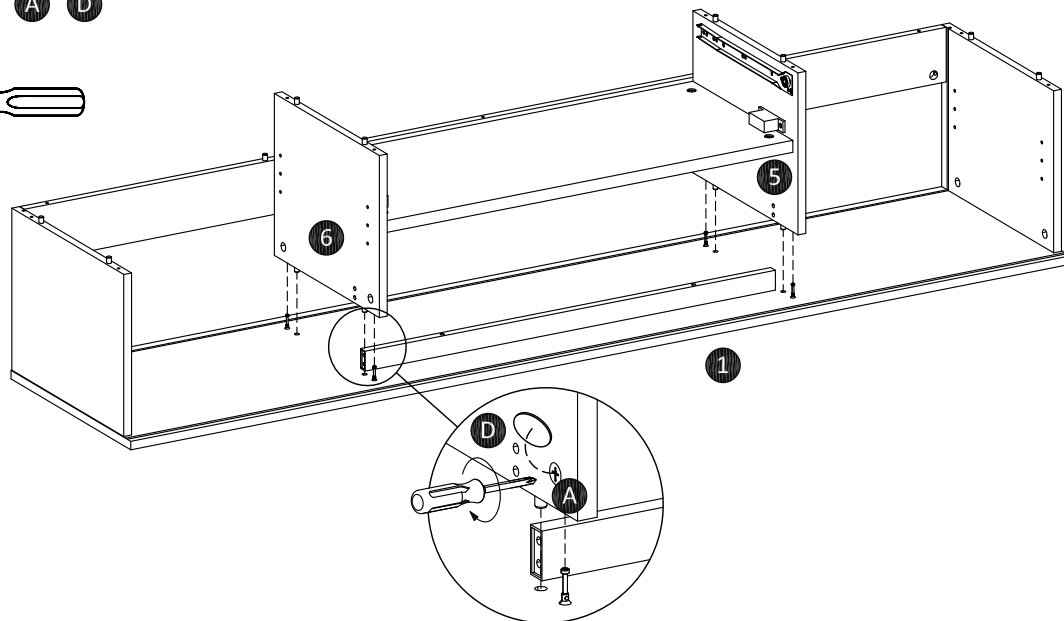
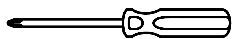

Attach divider assembly to case assembly as shown.
Turn the cam-lock (A) clockwise to lock using screwdriver, then paste cam-sticker (D).

Product assembly

Amara Media Unit - Oak Finish
SLAMATVMEL02

Step 9

Parts, fittings and tools

5 6 10 L

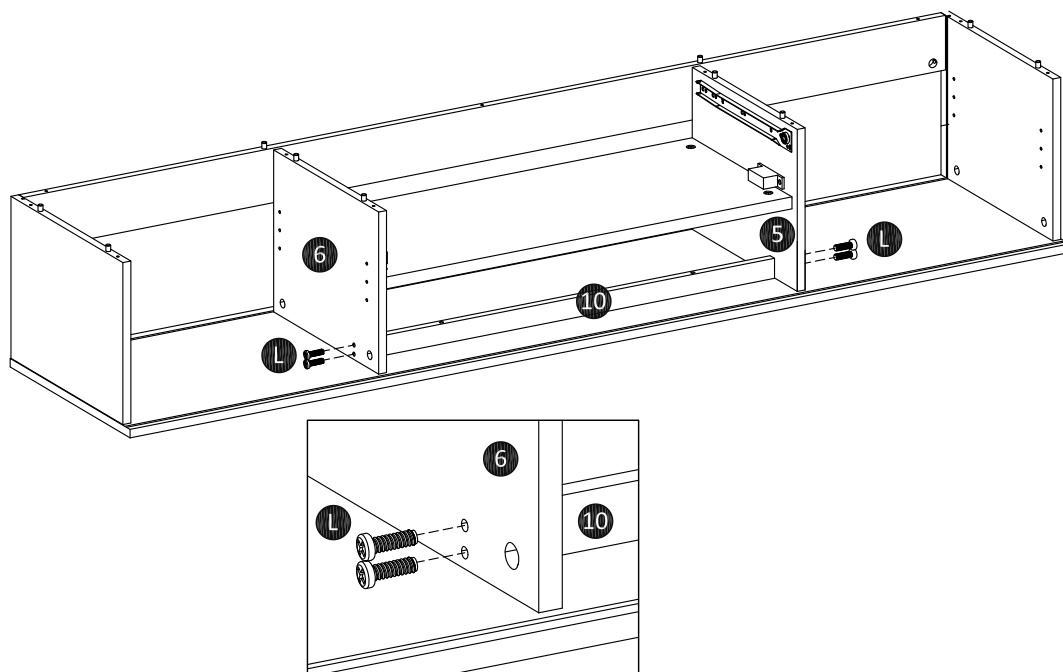
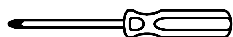

Strengthen top metal support (10) with the divider using screw (L).

Step 10

Parts, fittings and tools

11

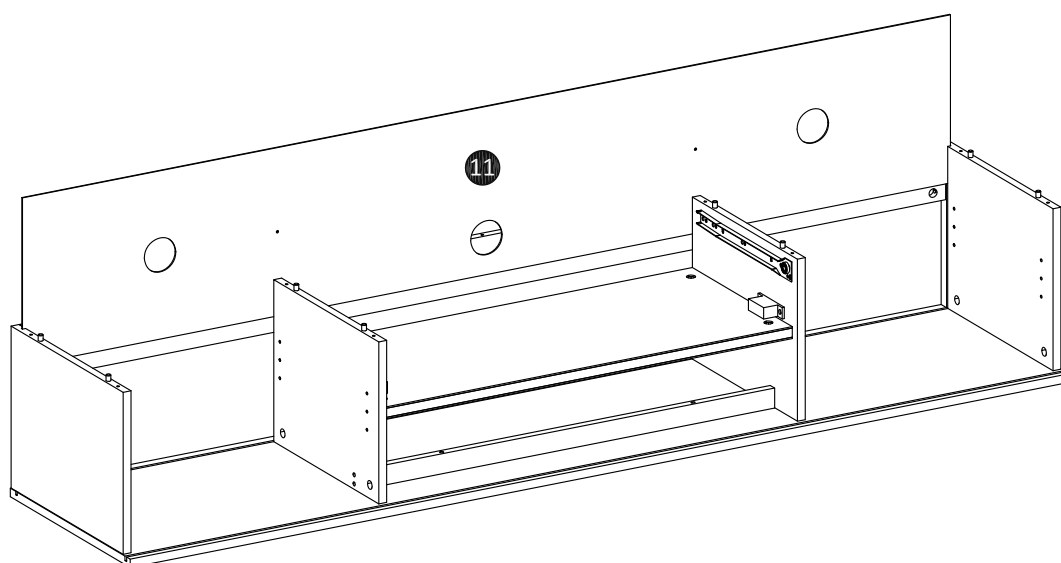
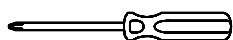

Insert backboard (11) into case assembly as shown.

Product assembly

Amara Media Unit - Oak Finish
SLAMATVMELO2

Step 11

Parts, fittings and tools

2 12 13 F G Q

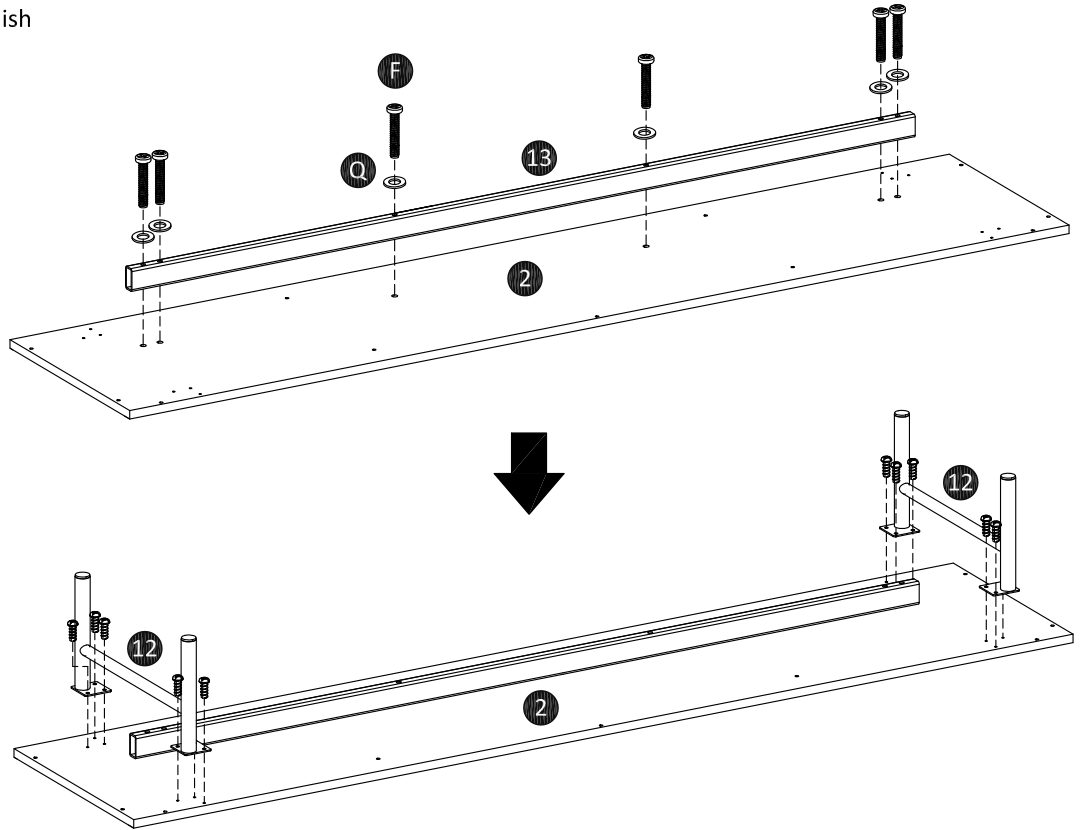
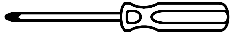

Attach bottom metal support (13) to bottom panel (2) using screw (F) and washer (Q).
Attach metal leg (12) to bottom panel (2) using screw (G).

Step 12

Parts, fittings and tools

2 3 4 5 6 J

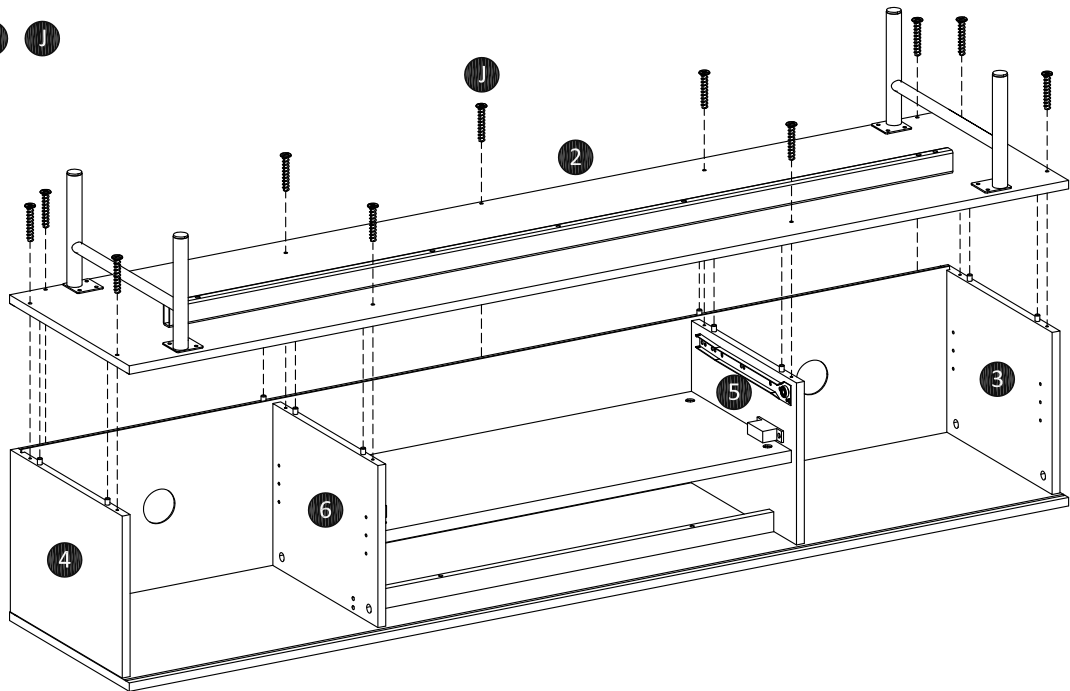
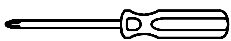

Attach bottom panel (2) to case assembly using screw (J).

Product assembly

Amara Media Unit - Oak Finish
SLAMATVMELO2

Step 13

Parts, fittings and tools

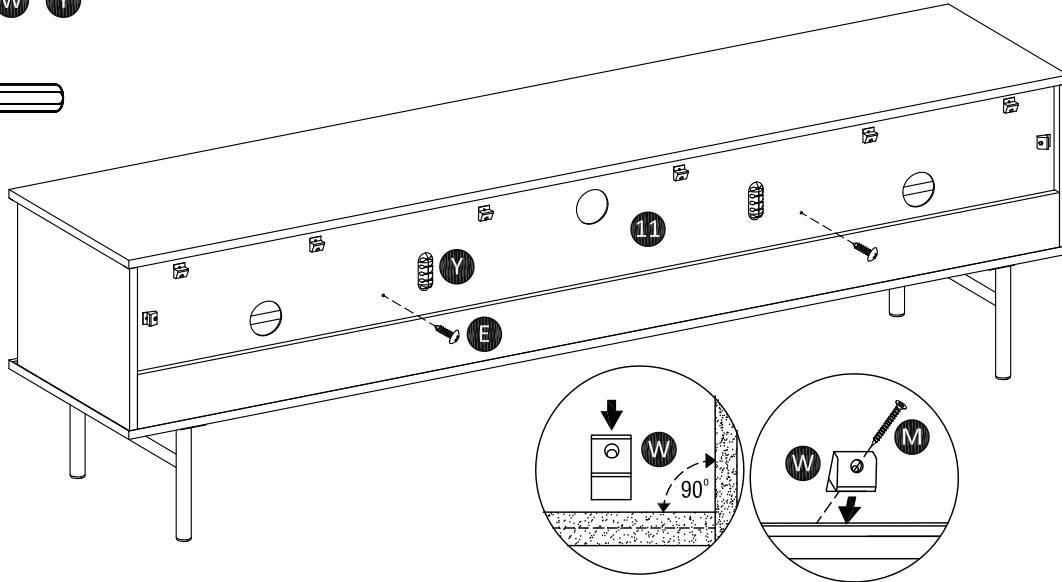
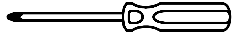

Attach backply stopper (W) to backboard (11) using screw (M).
Strengthen backboard (11) with screw (E) as shown.
Paste cable clamp (Y) on the backboard (11) as shown.

Step 14

Parts, fittings and tools

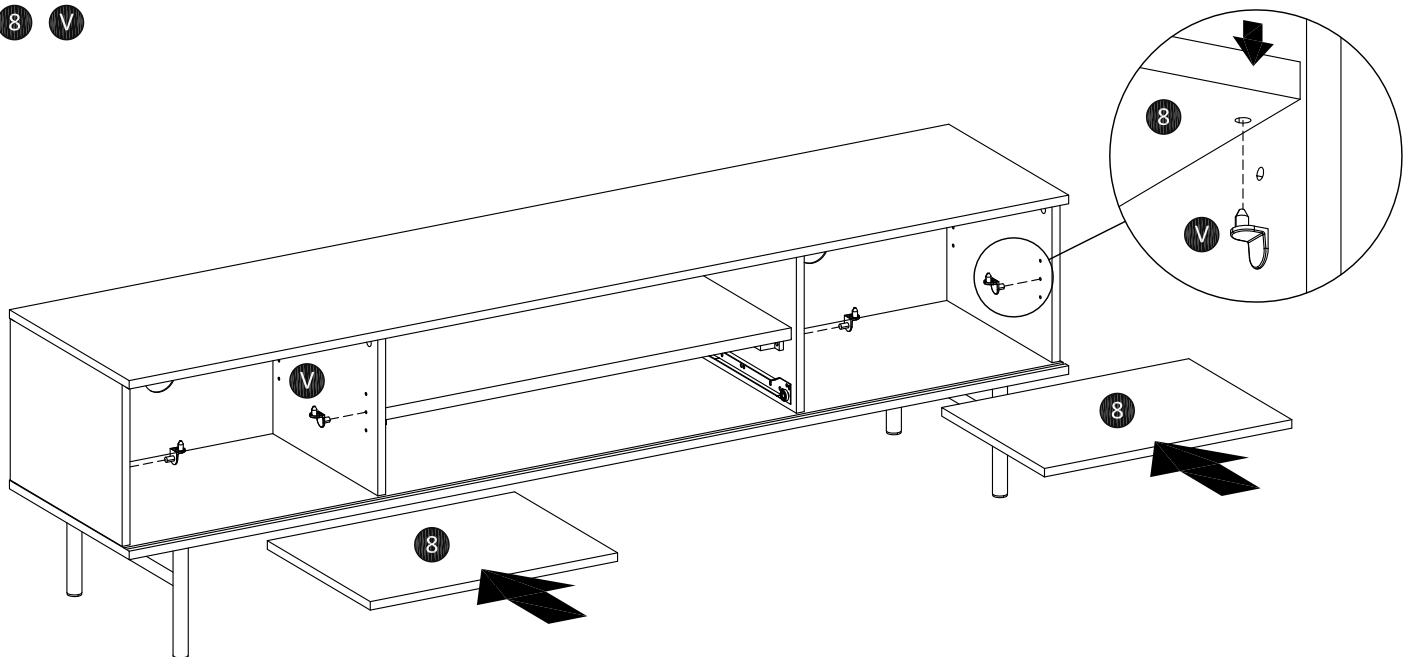

Insert shelf support (V) into case assembly as shown.
Insert adjustable shelf (8) into case assembly as shown.

Product assembly

Amara Media Unit - Oak Finish
SLAMATVMELO2

Step 15

Parts, fittings and tools

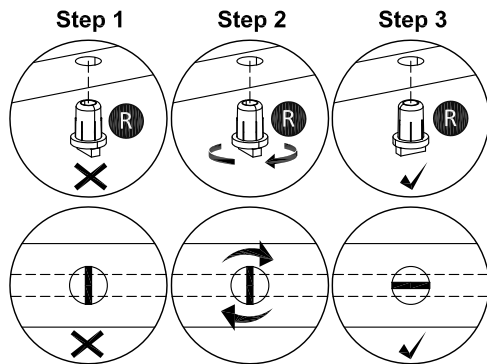
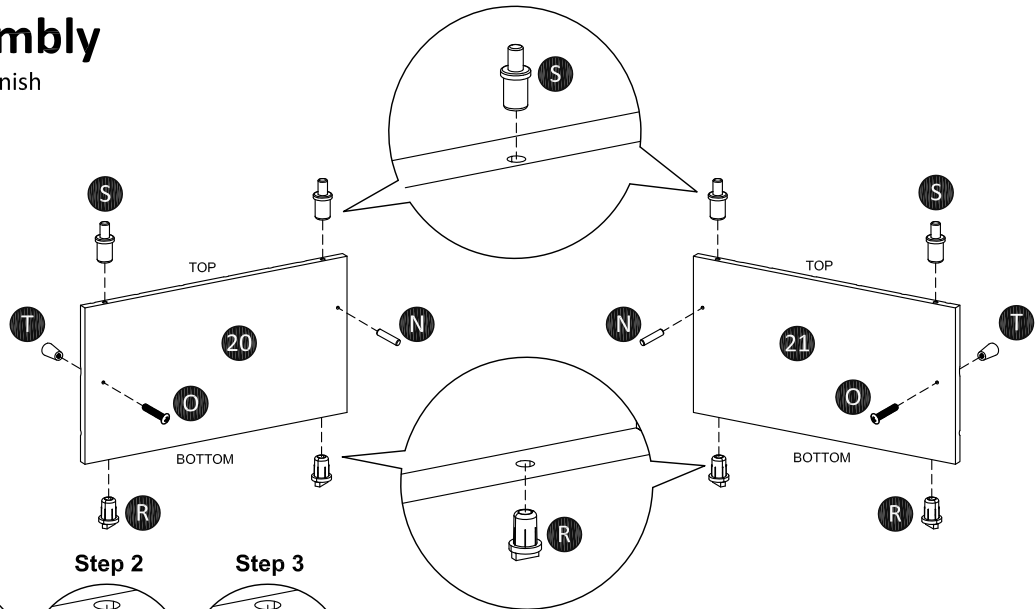
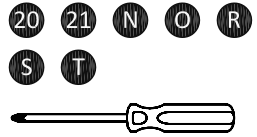

Insert push pin (S) in top of left door (20) and right door (21) while fix pin (R) in the bottom as shown.
Insert door stopper (N) in the left door (20) and right door (21) as shown.
Attach handle (T) to left door (20) and right door (21) using screw (O).

Step 16

Parts, fittings and tools

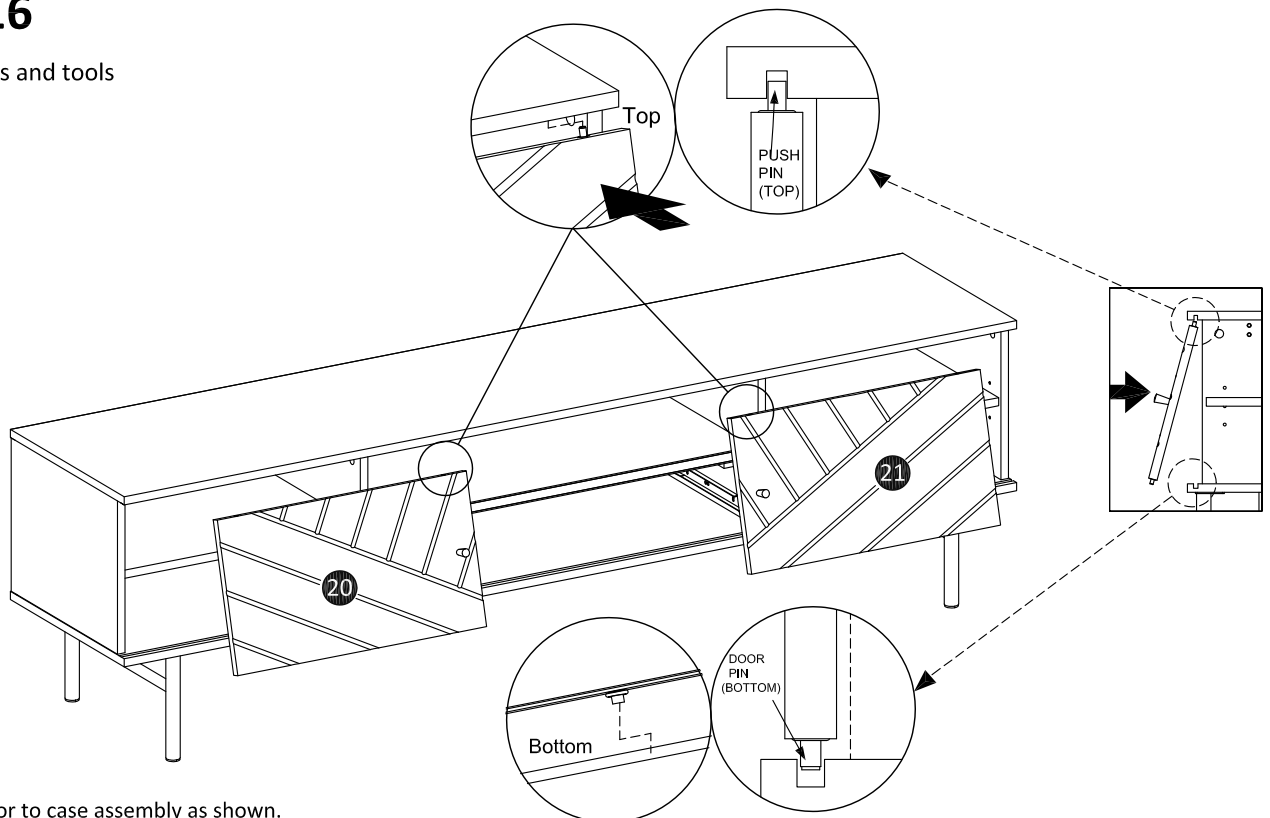

Install the door to case assembly as shown.

Product assembly

Amara Media Unit - Oak Finish
SLAMATVMEL02

Step 17

Parts, fittings and tools

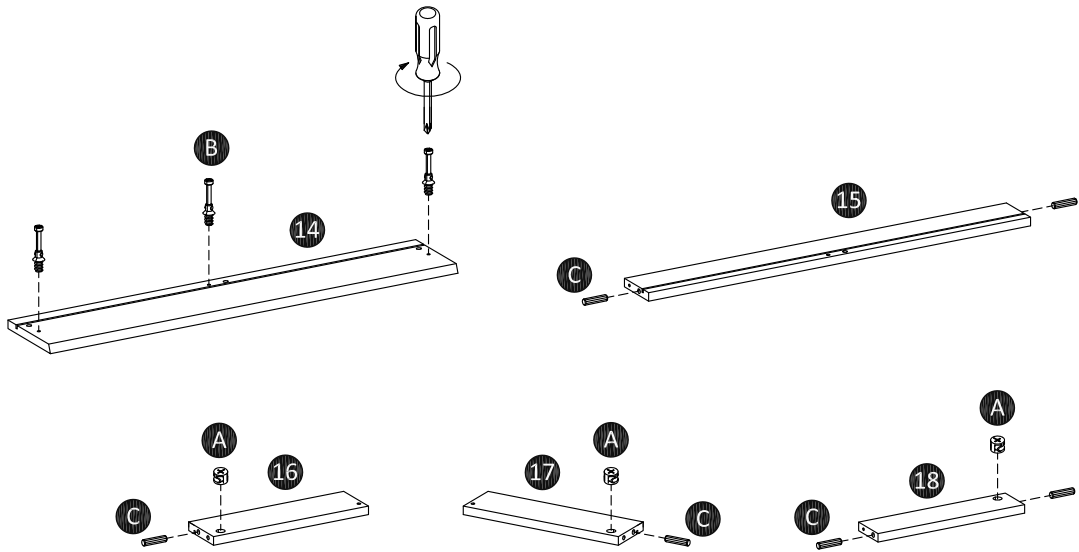
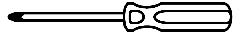
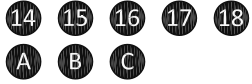

Attach cam-bolt (B) front drawer (14) using screwdriver.
Insert cam-lock (A) into left drawer (16), right drawer (17) and bottom support drawer (18).
Insert plastic dowel (C) into rear drawer (15), left drawer (16) and right drawer (17).

Step 18

Parts, fittings and tools

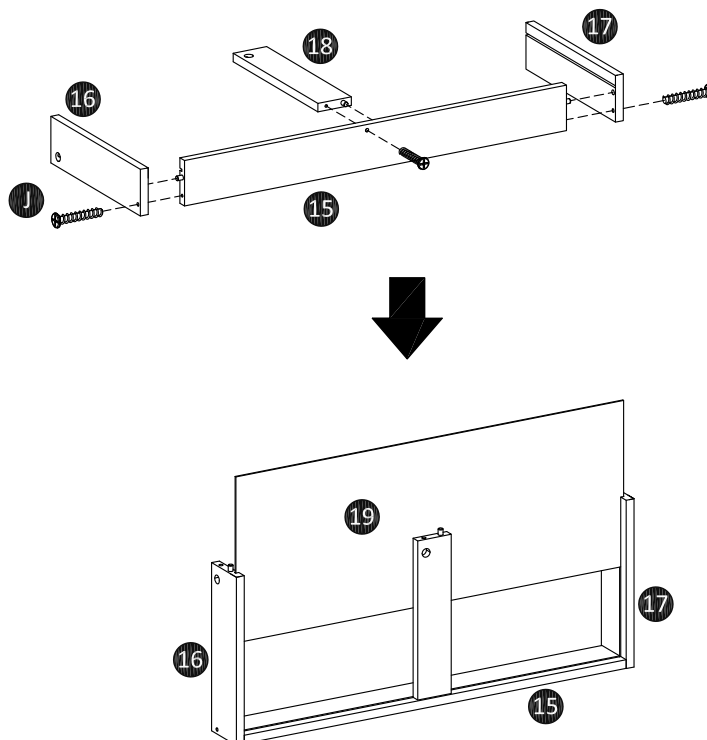
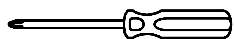

Attach left drawer (16) and right drawer (17) to rear drawer (15) using screws (J).
Insert bottom drawer (19) into assembly drawer as shown.

Product assembly

Amara Media Unit - Oak Finish
SLAMATVMEL02

Step 19

Parts, fittings and tools

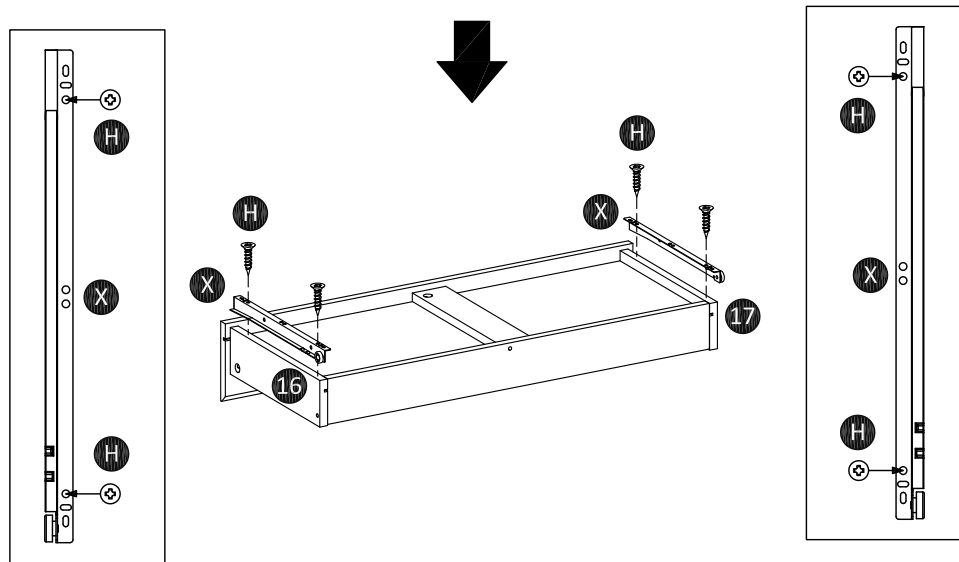
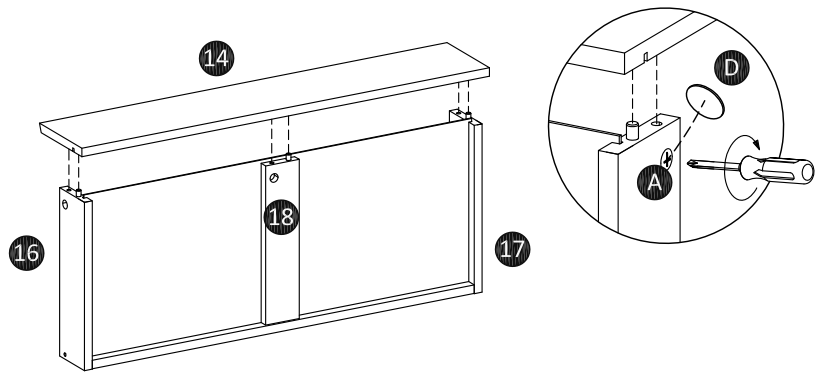
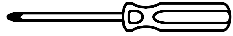

Attach front drawer (14) to assembly drawer as shown.
Turn the cam-lock (A) clockwise to lock using screwdriver, then paste cam-sticker (D).
Attach drawer rail (X) to left drawer (16) and right drawer (17) using screw (H).

Step 20

Parts, fittings and tools

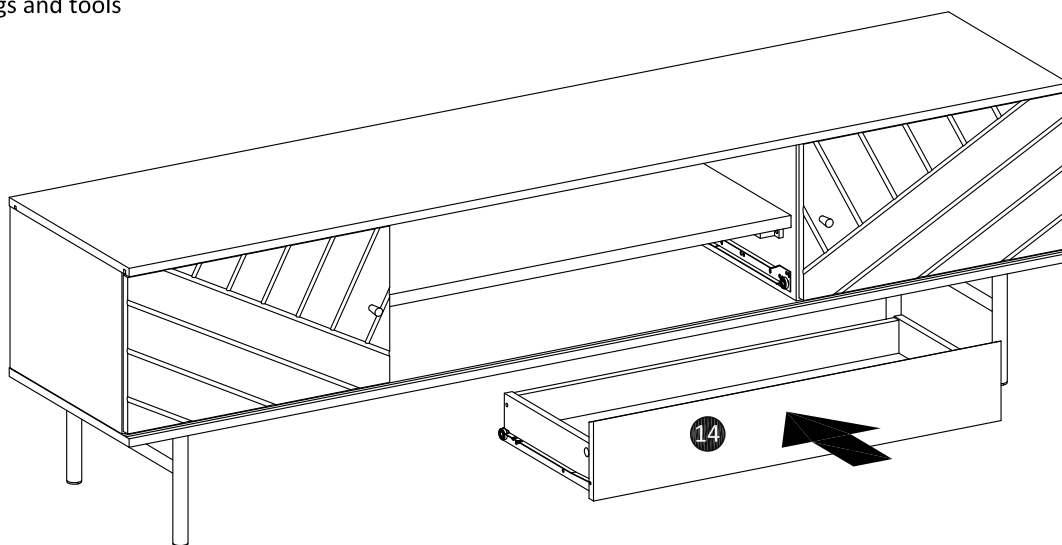

Insert assembly drawer into case assembly as shown.

Product assembly

Amara Media Unit - Oak Finish
SLAMATVMEL02

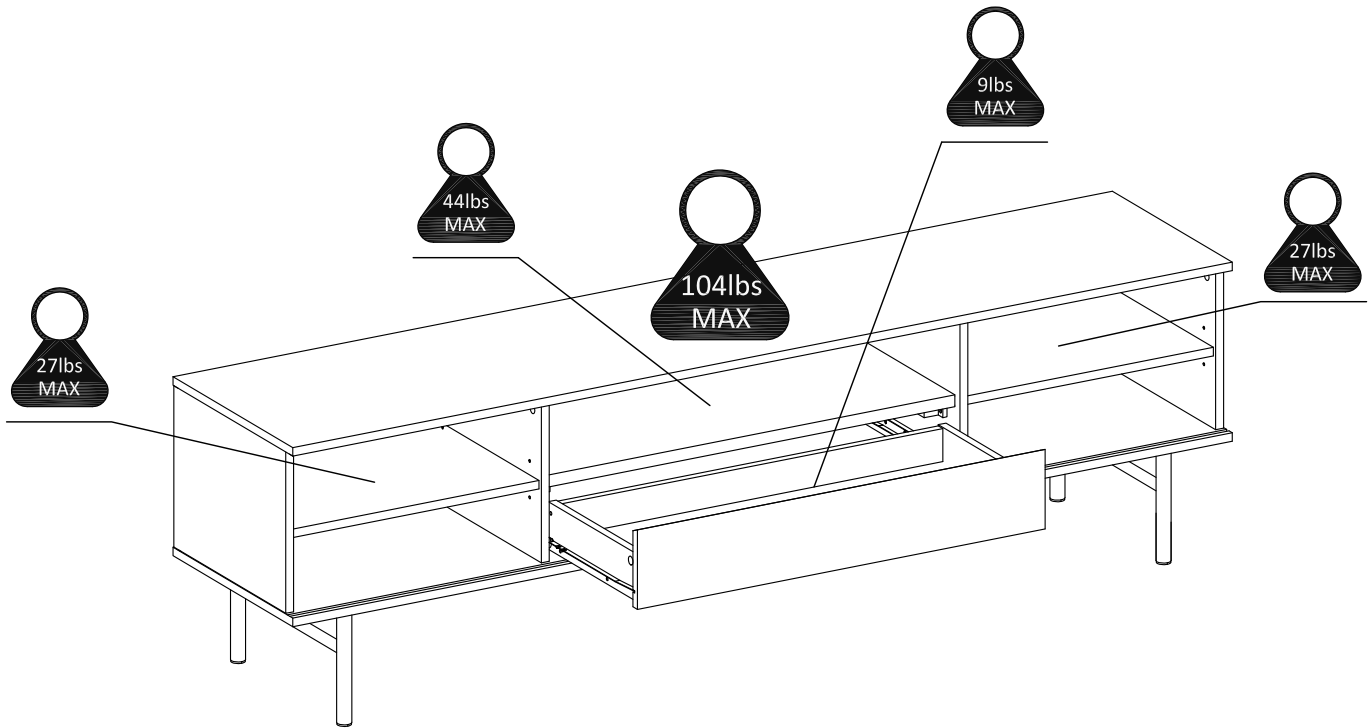

Care and maintenance

Wood furniture

Wood displays different grain patterns depending on which way they are cut - for example, the 'medullary ray' which can appear on oak furniture is a mark of good quality timber - these are just characteristics of natural beauty of the wood. Some furniture is also deliberately aged and rustic, wood veneers also allow a distinctive pattern to be created on some surface, such as tabletops and drawer fronts by the way slivers are arranged.

How to care for your wood furniture

Furniture with a hard lacquer, wax polish or painted surface should be dusted with a dry cloth. Waxed furniture will need to be given a coat of beeswax a couple of times a year to help maintain its lustre.

Spray polishes are best avoided as they contain silicones which may spoil the furniture's surface when building up over time.

Make sure all surfaces are protected from the heat and liquids by mats and coasters. Wipe up spills immediately and ensure that a mat or pad is placed under paper if you are writing.

Our furniture will endure most temperatures in the home, but it is best to avoid placing furniture next to heat sources such as radiators or fires. Be particularly careful with solid wood as the lack of humidity caused by home heating can cause damage such as warping.

Caution

This wood has a painted surface that can scratch. Please avoid contact with hard, sharp objects, Avoid placing plant pots or vases without waterproof mats to prolong the life of the product.

Please do not sit or lean on this product.

Maximum Load Capacity: 104 lbs for the top surface, 44 lbs for the central shelf, 27 lbs for each shelf and 9 lbs for the drawer.

Retain these instructions for furniture reference.

Your feedback is very important to us and we would love to hear your comments on your new furniture. Please visit our website to leave a review. Thank you.